

Name:

Target Grade:

Actual Grade:



MOVEMENT OF SUBSTANCES

MCQ and STRUCTURED QUESTIONS

READ THESE INSTRUCTIONS FIRST**INSTRUCTIONS TO CANDIDATES**

1. Find a quiet, comfortable spot free place from distractions.
2. Spend one minute on each mark.
3. Time yourself for every single question.
4. Every chapter has their own question types. Ensure that you know the different question type for each chapter.
5. Make a conscientious effort to remember your mistakes, especially in terms of answering techniques. E.g Take a picture for the mistakes that you made, keep it in a photo album, and revise it over and over again.
6. Highlight question types that you tend to keep making mistakes and review them nearing exams.
7. Always review the common questions and question type that you tend to make mistakes nearing exams.
8. During exams, classify the question type and recall what you have learnt, how you need to analyse the questions for the different question type, what you need to take note of and answer with the correct answering techniques!

✦ Wishing you all the best for this test!

You've got this!

💡 With lots of love,
Bright Culture 🧡

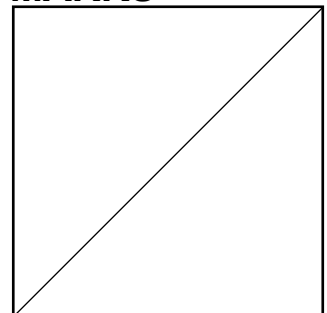

**GOOD LUCK
FOR YOUR EXAM!**

MARKS

MOVEMENT OF SUBSTANCES MCQ

- 1 In an experiment, several Chinese leek stalks were cut longitudinally into partial halves. The diagram below shows a freshly cut leek stalk.



The cut leek stalks were immersed in sucrose solutions of differing concentrations for an hour. The diagram below shows the results of this experiment.

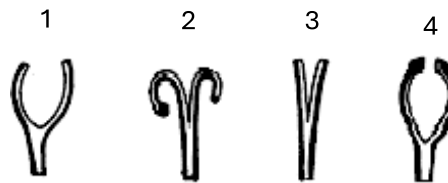

Which of the following shows the correct concentration of the sucrose solution in which the respective cut leeks have been immersed in?

	highest	—————→			lowest
A	4	1	3	2	
B	4	2	3	1	
C	2	3	1	4	
D	2	4	1	3	

- 2 The graph below shows the percentage changes in mass when four potato strips were cut from a freshly potato and immersed in sucrose solutions of different concentrations W, X, Y and Z.

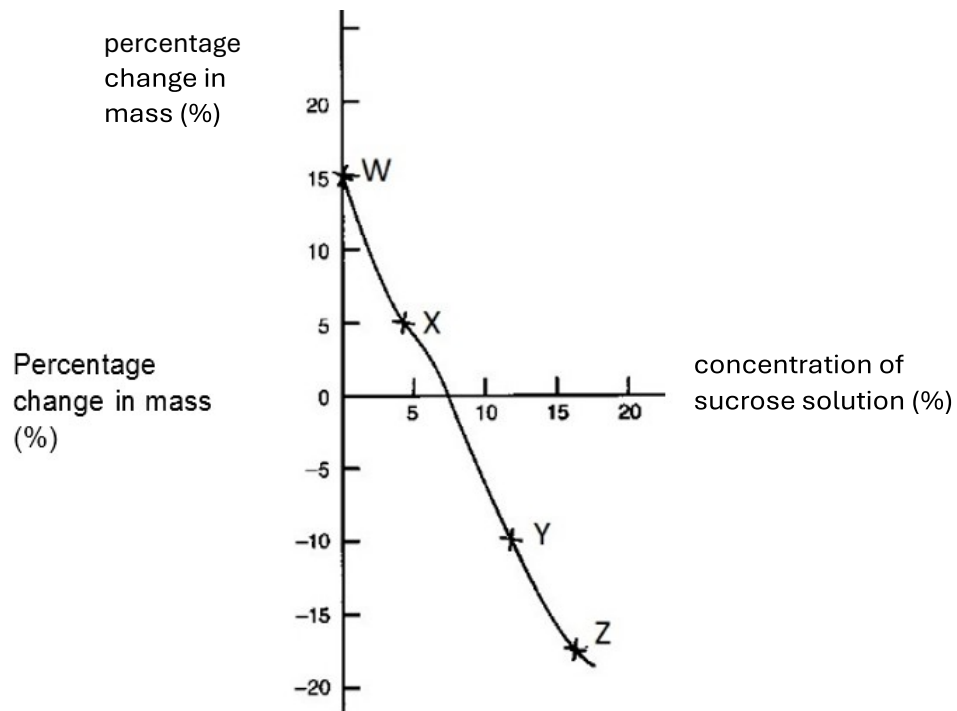

Cell sap of the potato is more concentrated than sucrose solution at

- A W only.
 - B W and X.
 - C Y and X.
 - D X, Y and Z.
- 3 The small intestine of person X contains a lower concentration of glucose than that present in the bloodstream.

Which statement best describes the movement of glucose in person X?

- A Glucose is absorbed into the bloodstream down the concentration gradient by active transport.
- B Glucose is absorbed into the bloodstream against the concentration gradient by active transport.
- C Glucose in the bloodstream moves into the small intestine down the concentration gradient by diffusion.
- D There is no net movement of glucose molecules until the concentration of glucose in the small intestine increases in person X after he has had a meal.

- 4 A student cuts out four cylinders of potato. The cylinders are all of the same length and the same diameter. The mass of each cylinder is measured before they are placed in sugar solutions of different concentrations. After one hour, the mass of the cylinders are measured again.

The results are shown in the table.

Which sugar solution has a water potential **closest** to that of the potato cells?

	concentration of sugar/ mol per dm ³	starting mass/ g	mass after 1 hour/ g
A	0.1	3.26	3.52
B	0.3	3.22	3.25
C	0.4	3.05	3.15
D	0.6	3.18	2.94

- 5 Four clear agar blocks (**A** to **D**) were placed into solutions of methylene blue of different concentrations as shown below.

Which of the following will be the **last** to be stained completely?

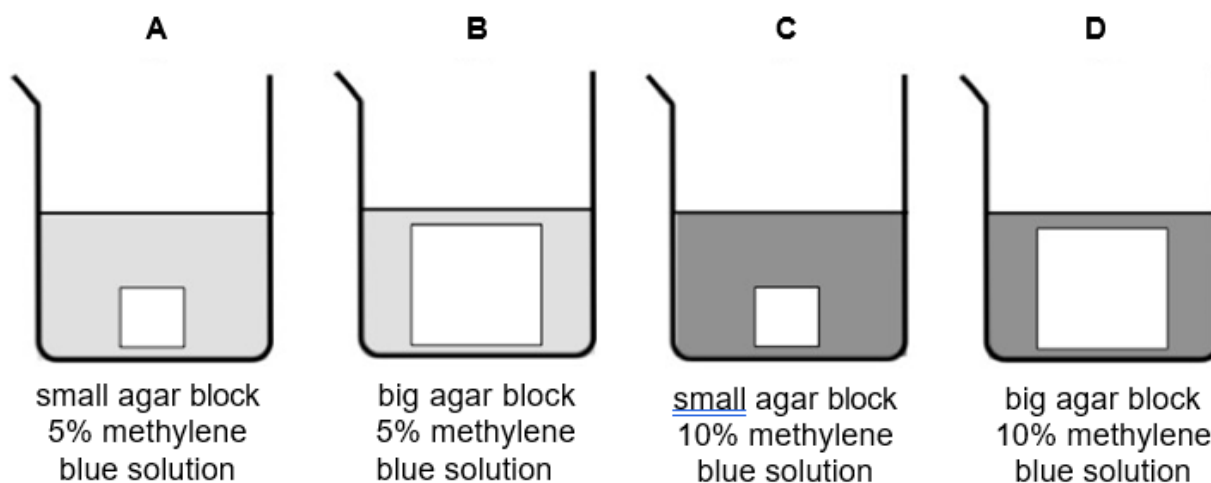

- 6 The table below shows the results from an investigation of the absorption of digested food in the presence and the absence of oxygen.

type of digested food	absorption in the presence of oxygen/ arbitrary units	absorption in the absence of oxygen/ arbitrary units
fatty acids	1.8	1.7
glucose	7.0	2.3
amino acids	6.2	2.4
glycerol	4.5	4.6

Which of the following describes the results obtained from the investigation?

- A** All the digested food is absorbed by active transport and diffusion.
- B** Amino acids are absorbed by active transport and diffusion.
- C** Fatty acids and glycerol are mainly absorbed by active transport.
- D** Glucose are absorbed by active transport only.
- 7 What is the main disadvantage of a spherical cell doubling its diameter without dividing?
- A** The amount of food diffusing into the cell is increased.
- B** The effectiveness of diffusion is reduced.
- C** The nucleus is not able to fully control the cellular activities.
- D** There is an increase in volume for stored food.
- 8 Which is an example of osmosis?
- A** a towel becoming wet when placed in water
- B** cucumber slices shrinking in size when soaked in brine during pickling
- C** mineral salts being absorbed by root hair cells
- D** oxygen moving into red blood cells

- 9 An experiment was carried out to measure the rate at which two plants take up magnesium ions from solution. Poison was applied to the soil of one pot of plant. The other plant was left as it is. The graph shows the results.

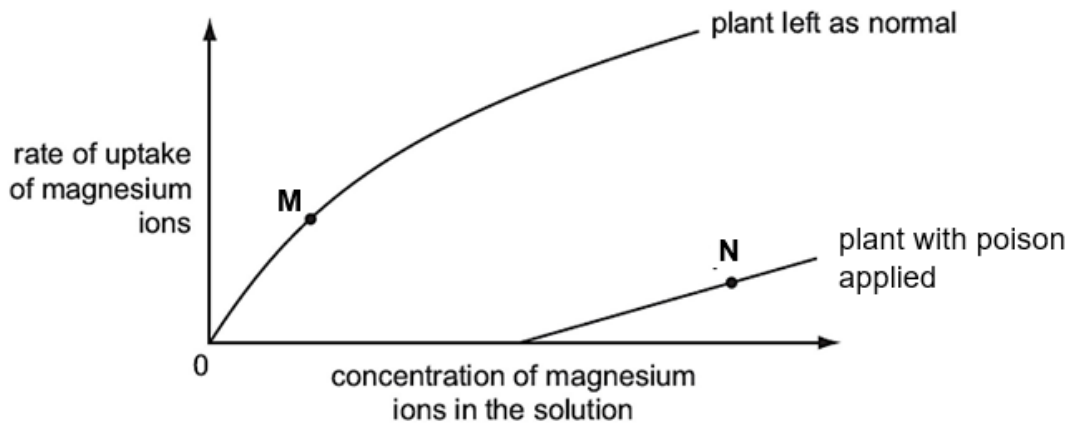

By which processes do the plants absorb magnesium ions at points **M** and **N**?

	point M	point N
A	active transport	active transport
B	active transport	diffusion
C	diffusion	active transport
D	diffusion	diffusion

- 10 A student conducting the experiment left the setup shown below for one hour. What would the levels of solution in the well of the potato and the petri dish be like after the hour?

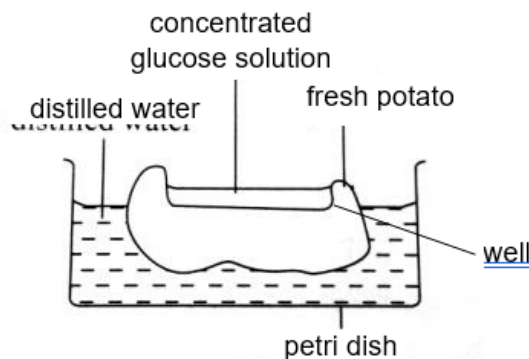

	well	petri dish
A	higher	higher
B	higher	lower
C	lower	higher

D	lower	lower
----------	-------	-------

11 The accompanying diagram shows a Visking tubing cell model set up to investigate the process of osmosis.

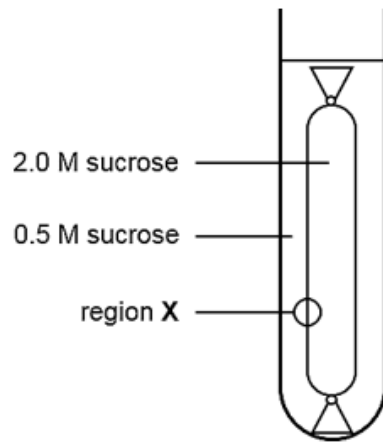

Which of the diagrams below most accurately represents region X at a molecular level?

A

sucrose molecule water molecule

B

partially permeable membrane

C

D

→ = direction of net movement of water molecules

- 12 Strips of plant tissue were immersed in a range of sucrose solutions of different concentrations. Their lengths were measured before immersion and after 30 minutes in the different concentrations.

The graph shows the ratio of the initial length to final length.

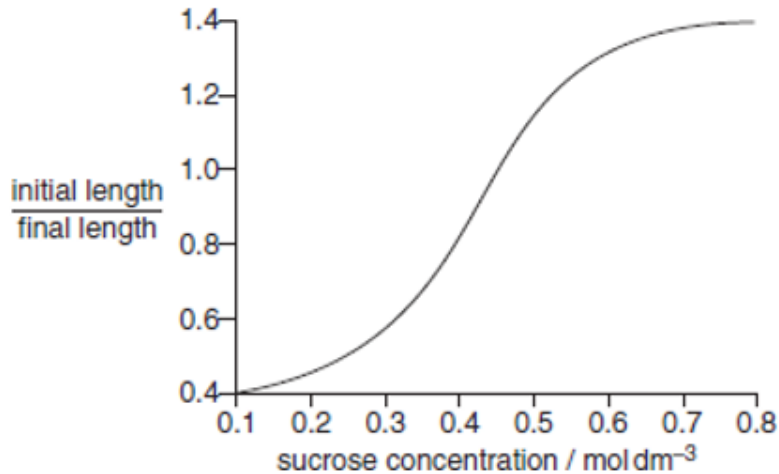

Which concentration of sucrose solution, in mol dm⁻³, has the same water potential as the cell sap before immersion?

- A** 0.1 **B** 0.25 **C** 0.45 **D** 0.8
- 13 The table shows the results of an investigation into the absorption of products of digestion in the presence and absence of oxygen.

product of digestion	absorption in the presence of oxygen/ arbitrary units	absorption in the absence of oxygen/ arbitrary units
amino acids	5.3	1.7
fatty acids	1.9	2.0
glucose	6.4	2.3
glycerol	4.8	4.7

Which conclusion can be drawn from these results?

- A** All products of digestion are absorbed by both active transport and diffusion.
B All products of digestion are absorbed by diffusion only.
C Amino acids and glucose are absorbed by active transport only.
D Fatty acids and glycerol are absorbed mainly by diffusion.

14 The diagram shows a model which can be used to demonstrate translocation.

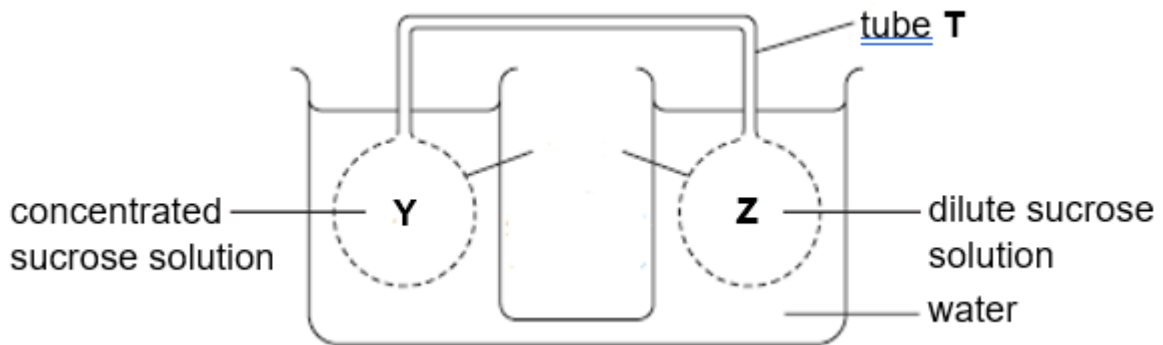

Y and Z are filled with sucrose solutions of different concentrations, causing water molecules to move in or out of Y and Z by osmosis or as a result of hydrostatic pressure. Sucrose solution then moves through the tube T joining Y and Z.

Which description of this is correct?

	water potential in Y compared to Z	direction of movement of sucrose solution in tube T
A	higher	from Y to Z
B	higher	from Z to Y
C	lower	from Y to Z
D	lower	from Z to Y

15 The diagrams show the processes by which molecules move in living organisms.

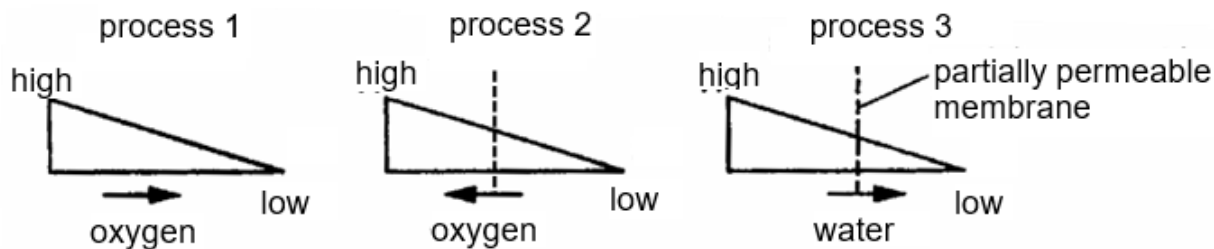

- = concentration gradient of molecules
- high = high concentration of molecules
- low = low concentration of molecules
- = direction of movement of molecules (oxygen or water)

Which of the following is correct?

	active transport	diffusion	osmosis
A	1	2	3
B	2	3	1
C	2	1	3
D	3	2	1

16 The table shows the mass of four types of nutrients, P, Q, R and S, absorbed by the roots of a plant in the presence and absence of oxygen in one hour.

	mass absorbed in presence of oxygen / g per hr	mass absorbed in absence of oxygen / g per hr
P	3.5	3.2
Q	4.4	0.9
R	0.8	0.7
S	2.4	1.5

Which of the following conclusions can be made from the data?

- A** Nutrients P and Q are mainly absorbed by diffusion.
- B** Nutrients P, Q and S are absorbed through both diffusion and active transport.
- C** Nutrients Q and S are mainly absorbed through active transport.
- D** Nutrients P, Q, R and S are absorbed only through active transport.

- 17 The table below shows the rate at which two sugars are absorbed into the lining of a healthy intestine and an intestine that has been subjected to a respiratory poison.

type of sugar	rate of absorption / arbitrary units	
	healthy intestine	poisoned intestine
glucose	120	43
maltose	39	39

From the data, how do the two sugars enter the intestine in a healthy intestine?

	glucose	maltose
A	active transport	active transport
B	active transport	diffusion
C	diffusion	diffusion
D	diffusion	active transport

- 18 Which of the following explains the importance of osmosis in plant roots?
- A It helps to control body temperature.
 - B It helps to ensure root hair cells remain flaccid.
 - C It provides the fluid needed for respiration to occur.
 - D It provides the solvent needed to transport mineral salts.

- 19 Four identical pieces of carrot are treated in two stages as shown below.

Which piece of carrot will be the largest after 2 hours?

	stage 1	stage 2
A	boiled in water for 10 minutes	placed in 10% salt solution for 2 hours
B	boiled in water for 10 minutes	placed in distilled water for 2 hours
C	unboiled	placed in 10% salt solution for 2 hours
D	unboiled	placed in distilled water for 2 hours

20 The diagram shows how glucose molecules move from the tissue fluid into a cell.

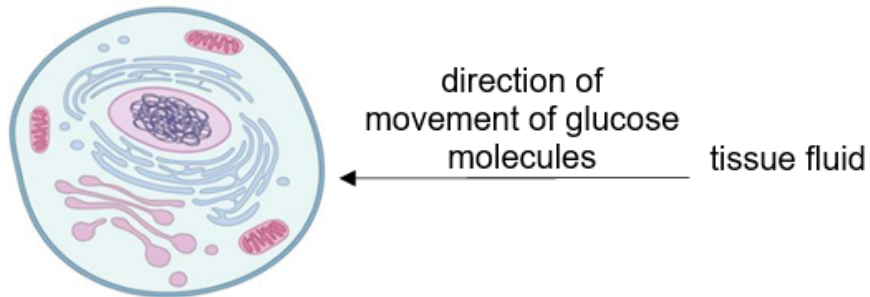

The table shows the amount of glucose present in the cell cytoplasm and tissue fluid under normal conditions and in the presence of a toxin which affects mitochondria function.

conditions	unit of glucose	
	cell cytoplasm	tissue fluid
normal	25	17
presence of toxin	17	17

Which process best describes how glucose molecules move into the cell?

- A** active transport
- B** diffusion
- C** osmosis
- D** translocation

21 Use the following graph to answer Questions 21 and 22.

The graph shows the effect of oxygen on the rate of mineral ion uptake by root hair cells

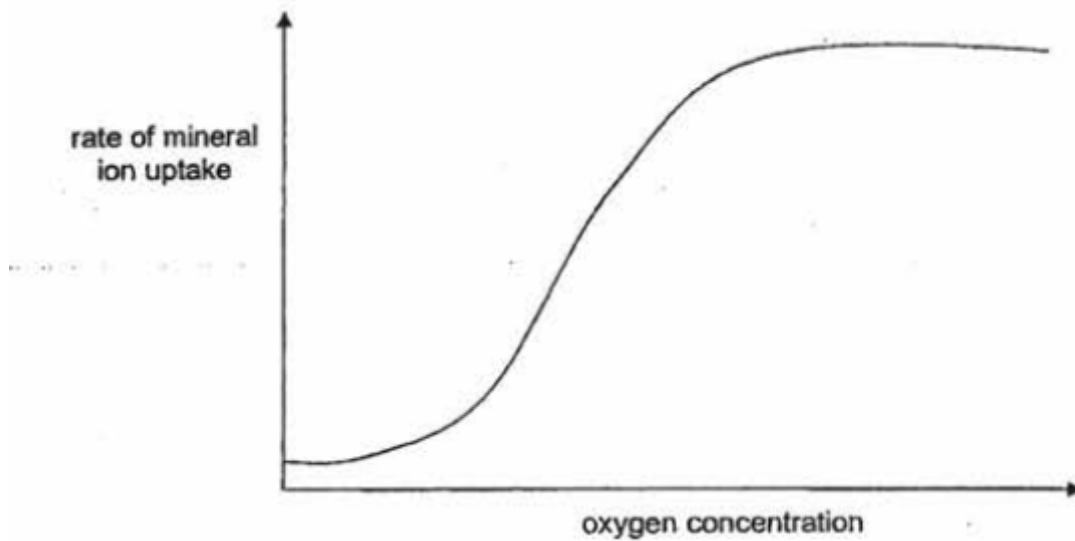

Which cell organelle in root hair cells is necessary for mineral ion uptake?

- A cell surface membrane
- B mitochondria
- C nucleus
- D ribosomes

22 Which process(es) is / are involved in mineral ion uptake by root hair cells?

- A active transport only
- B diffusion only
- C osmosis onl
- D active transport and diffusion only

23 A plant cell is immersed in distilled water.

Which statement explains why water moves into the cell?

- A The cell surface membrane is fully permeable.
- B The cellulose cell wall is partially permeable.
- C Water enters the cell by active transport.
- D Water moves down a water potential gradient.

24 The diagrams below show the states of plant cells soaked in solutions A and B after 30 minutes.

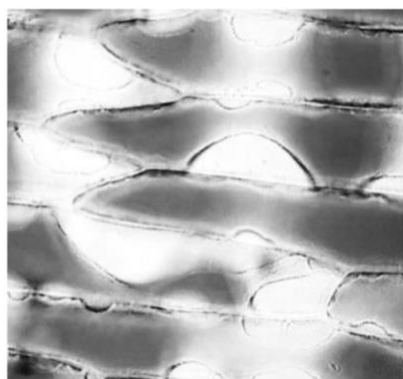

cells in solution A

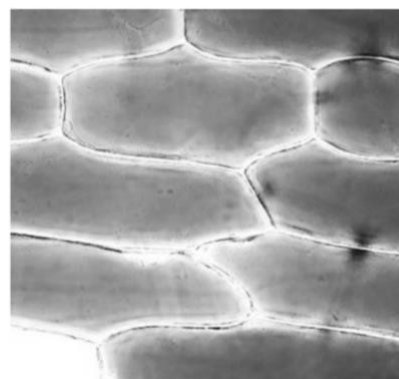

cells in solution B

What types of solutions are A and B to the cells?
 What is the process that cells in solution A have undergone?

	solution A	solution B	process in solution A
A	hypertonic	hypotonic	crenation
B	hypertonic	hypotonic	plasmolysis
C	hypotonic	hypertonic	cell lysis
D	hypotonic	hypertonic	haemolysis

25 *Paramecium*, a protozoan has two contractile vacuoles for the evacuation of excess water from its body. The table below records the average time taken by a contractile vacuole to empty its contents when the animal is immersed in 3 different liquids S, T and U.

Bathing liquid	Time / s
S	188
T	31
U	64

What are the three bathing liquids likely to be?

	S	T	U
A	0.3% salt solution	0.1% salt solution	water
B	0.1% salt solution	water	0.3% salt solution
C	water	0.3% salt solution	0.1% salt solution
D	0.3% salt solution	water	0.1% salt solution

- 26 An experiment measured the rate at which plants take up magnesium ions from solution. One plant was given a poison that stops respiration. Another plant was left as normal. The graph shows the results.

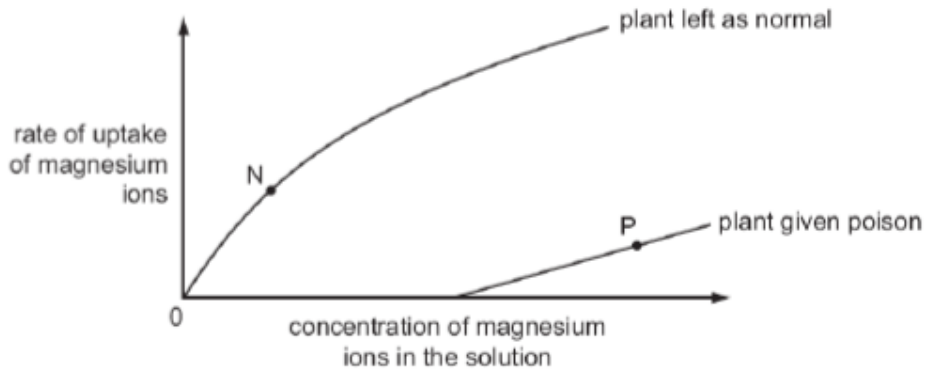

How are magnesium ions being absorbed by the plants at points N and P?

	N	P
A	diffusion only	active transport only
B	active transport only	diffusion only
C	diffusion and active transport	active transport only
D	diffusion and active transport	diffusion only

- 27 Pieces of potato of equal size were weighed and placed in different concentrations of sucrose solutions. After 24 hours, the potato pieces were removed and reweighed. For each potato piece, the initial mass divided by final mass was calculated.

Which graph correctly represents the change in initial mass divided by final mass of the potato pieces in sucrose solutions of different concentrations?

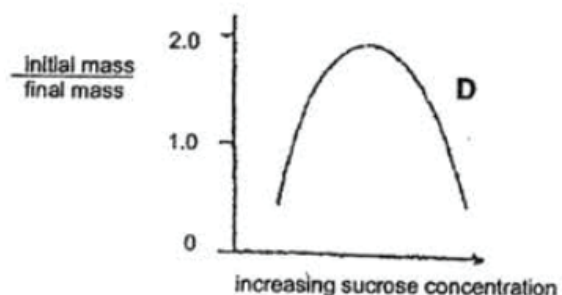
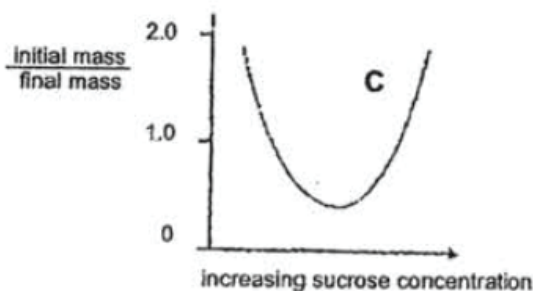
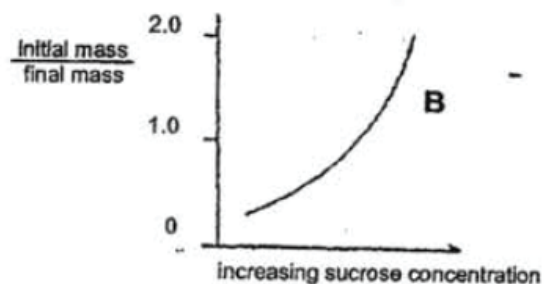
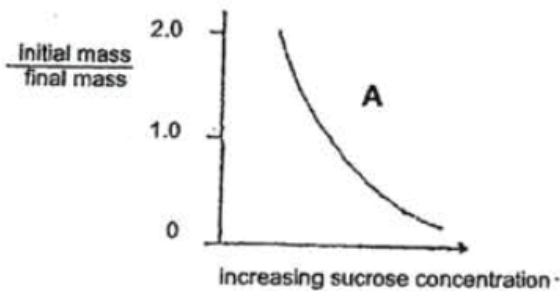

- 28 Which process involves active transport?
- A movement of ions up the xylem
 - B uptake of glucose by cells in the villi
 - C movement of water into root hairs
 - D uptake of oxygen in red blood cells
- 29 Which of the following shows an example of diffusion taking place in green plants?
- A Water molecule moving from cell to cell in the roots towards the xylem vessel.
 - B Sugars transported into storage organs with the aid of mitochondria.
 - C Water vapour moving out of the intercellular space of the leaves to the atmosphere via the stomata.
 - D Uptake of scarce mineral ions from the soil into the root hair cells with the expenditure of energy.
- 30 Strips of plant tissue were immersed in a range of sucrose solutions of different concentrations. Their lengths were measured before immersion and after 30 minutes in the different solutions. The graph shows the ratio of initial length to final length.

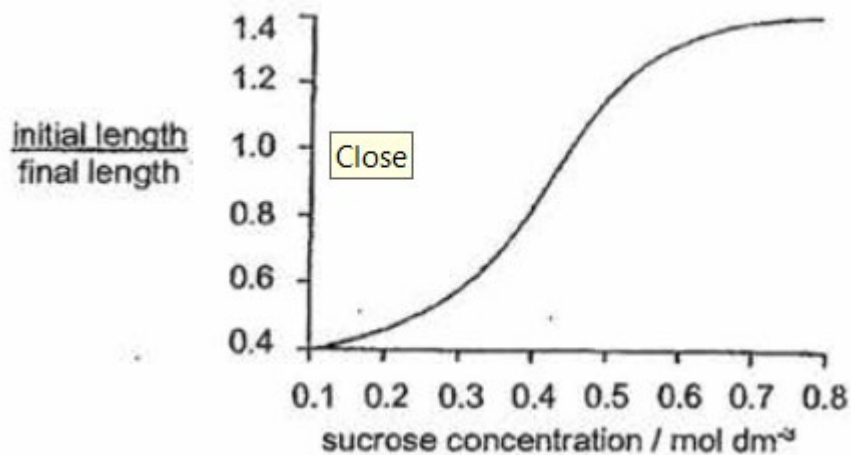

Which concentration of sucrose solution, in mol dm³, has the same water potential as the cell sap before immersion?

- A 0.1
- B 0.25
- C 0.45
- D 0.8

- 31 An experiment involving osmosis was conducted on plant cells.

The diagram shows a plant cell at the start of the experiment and after being immersed in a concentrated salt solution for 30 minutes.

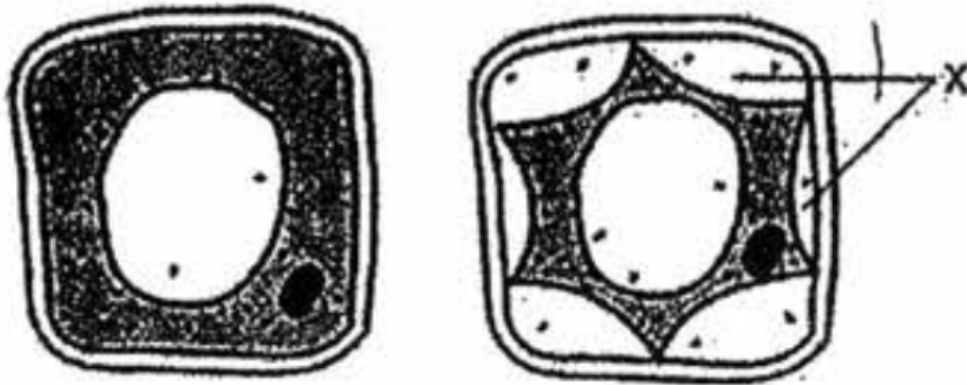

What is found in region X?

- | | | | |
|---|---------------|---|----------|
| A | air | B | cell sap |
| C | salt solution | D | water |
- 32 Which of the following would speed up the rate of diffusion?
- I: increasing temperature
II: increasing surface area for absorption
III: increasing volume for absorption
IV: increasing concentration gradient
- | | | | |
|---|------------|---|--------------|
| A | I and II | B | I, II and IV |
| C | II and III | D | IV only |
- 33 Potassium cyanide is a toxic chemical because it inhibits respiration. Which of the following would most likely happen if a root hair cell was treated with potassium cyanide?
- A uptake of water by osmosis would cease
B uptake of oxygen by diffusion would cease
C uptake of minerals by diffusion would cease
D uptake of minerals by active transport would cease

34 The diagram shows an experiment using a potato.

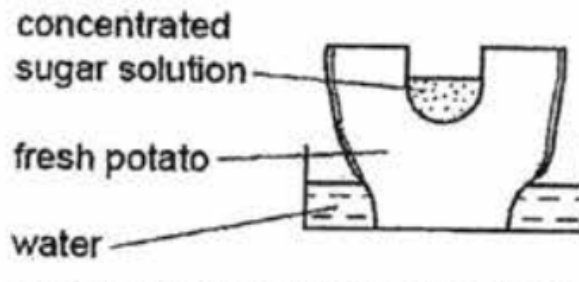

Which shows the results of the experiment after 24 hours?

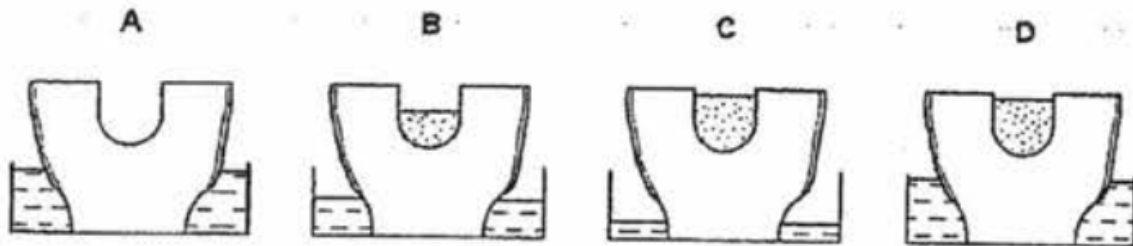

35 Three potato strips (X, Y and Z) with the same mass were placed into three different solutions. The mass of the three potato strips were then compared using a beam balance. The results are shown in the diagram below.

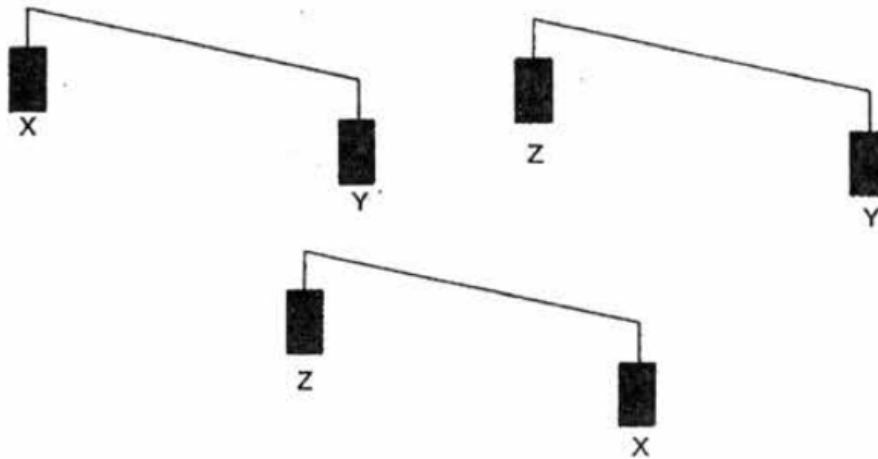

Which of the following solutions is the potato strips placed in?

	X	Y	Z
A	10% sucrose solution	25% sucrose solution	Pure water
B	10% sucrose solution	pure water	25% sucrose solution
C	25% sucrose solution	pure water	10% sucrose solution
D	25% sucrose solution	10% sucrose solution	Pure water

36 The diagrams show agar blocks, each completely immersed in a beaker of a solution of coloured stain.

Which block would be stained most rapidly?

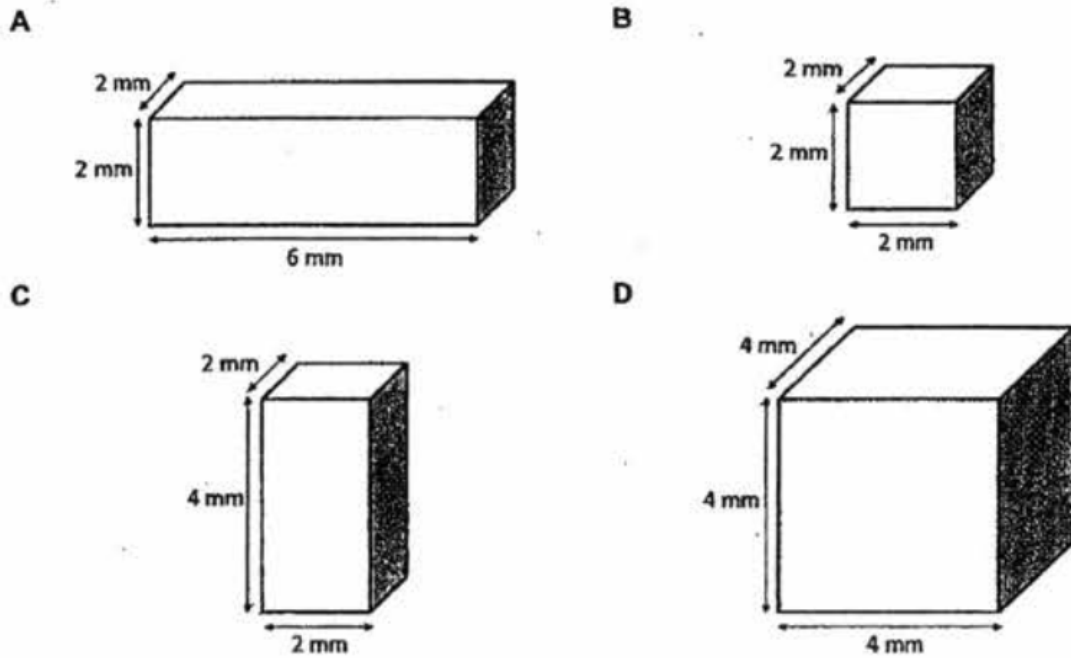

37 The diagram shows the procedure to prepare slides containing onion epidermis soaked in different liquids for 10 minutes before being observed under the microscope.

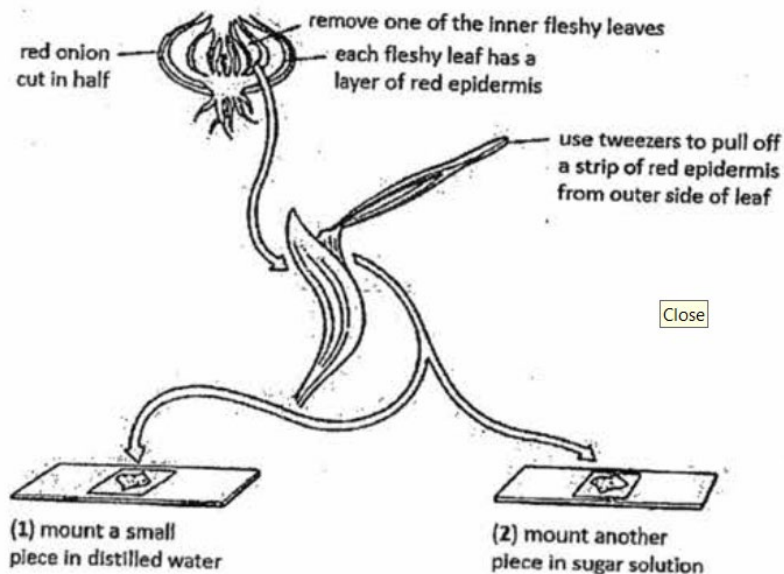

Which option most accurately describes the cells on slides 1 and 2?

	Slide 1	Slide 2
A	Turgid	Plasmolysed
B	Plasmolysed	Not visible
C	Turgid	Crenated
D	Crenated	Not visible

38 The diagrams below show three mammalian structures, and the blood supply to each by capillaries.

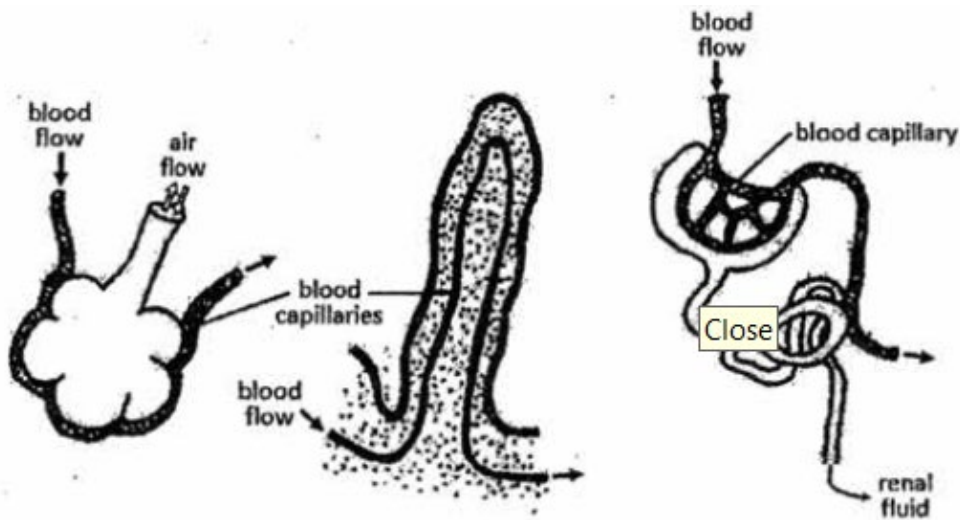

Some features describing the blood supply are listed:

- 1 All are highly branched and thin to supply to a larger surface area.
- 2 All are very near the exchange surface to enhance the exchange of substances.
- 3 All rely on active transport to carry out exchange of substances.
- 4 All have thin walls to enhance the exchange of substances.

Which of these are adaptive features that are commonly possessed by all the structures shown, to allow them to perform their functions efficiently?

- A 3 and 4
- B 2 and 4
- C 1,2 and 4
- D 1,3 and 4

39 The diagram represents the passage of water molecules and glucose molecules across a partially permeable cell surface membrane.

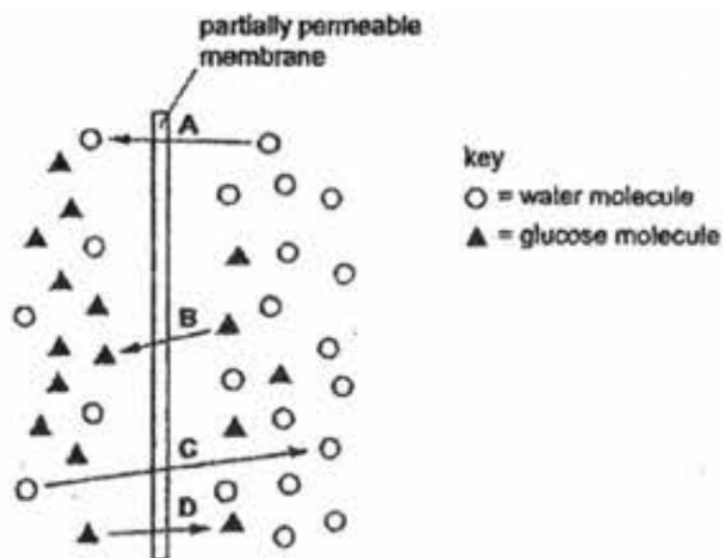

Which arrows indicates diffusion?

40 A student investigated osmosis in potatoes. He set up the apparatus shown.

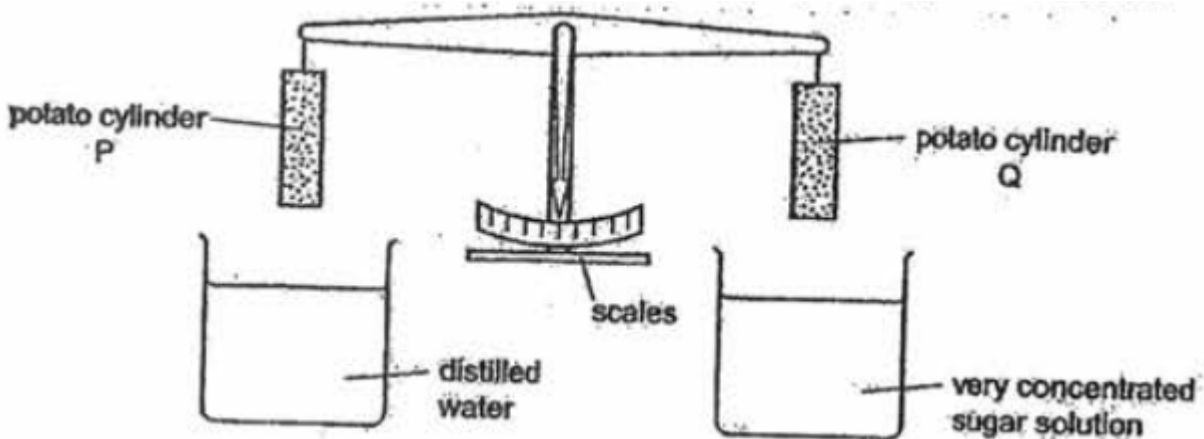

At the beginning the potato cylinders were exactly balanced. He immersed the cylinders into the liquids for 4 hours, after which the cylinders were lifted out of the liquids. Cylinder P was now heavier than cylinder Q.

Which statement explains what happened?

- A Water moved into both cylinders.
- B Water moved out of both cylinders.
- C Water moved into the cylinder in the distilled water and out of the cylinder in the sugar solution.
- D Water moved out of the cylinder in the distilled water and into the cylinder in the sugar solution.

41 The table below shows the mass of four particular nutrients (P, Q, R and S) absorbed by the roots of a plant in the presence and absence of oxygen in one hour.

nutrient	mass absorbed in the presence of oxygen/ g/hr	mass absorbed in the absence of oxygen/ g/hr
P	3.5	3.6
Q	4.4	0.9
R	0.8	0.7
S	2.4	1.5

42 Several plant roots were soaked for 24 hours in a metabolic poison that is known for reducing the activity of mitochondria. What is the expected effect on the absorption of water and mineral salts in the roots?

	absorption of water	absorption of mineral salts
A	no effect	no effect
B	no effect	slower
C	slower	slower
D	slower	no effect

43 The diagram represents an apparatus used to investigate osmosis.

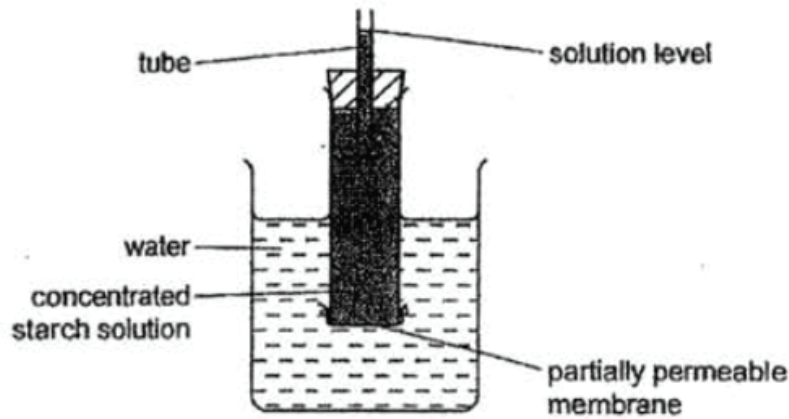

Which molecules will move across the partially permeable membrane and which change will occur in the solution level?

	Molecules	solution level
A	starch	fall
B	starch	rise
C	water	fall
D	water	rise

44 The diagram shows a typical plant cell after being placed in a concentrated salt solution.

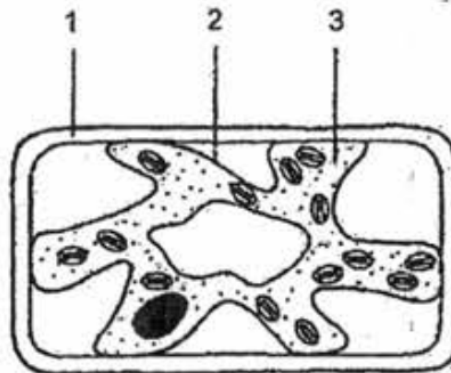

Which numbered structure(s) are partially permeable?

- A 1 only
- B 2 only
- C 1 and 2 only
- D 1 and 3 only

45 Which processes can take place in a root hair cell when oxygen is not available?

- A active transport only
- B diffusion only
- C active transport and osmosis
- D diffusion and osmosis

46 A tissue composed of plasmolysed plant cells was put into distilled water. The graph shows how the mean cell volume changes with time.

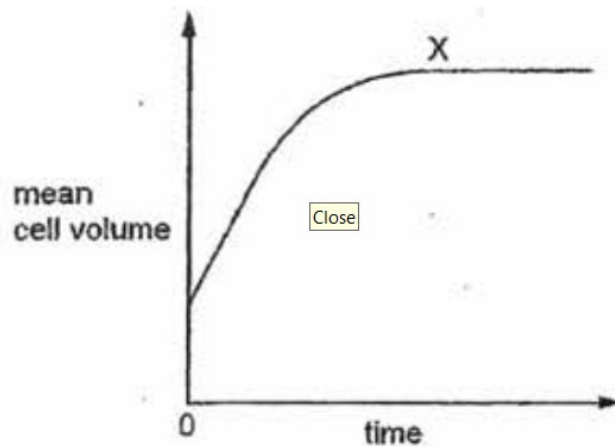

What is the cause of the plateau at X?

- 1 water potential in the plant cell has become more negative
- 2 cells have become fully turgid
- 3 no net movement of water into cells

- A 1, 2 and 3
- B 1 and 2 only
- C 1 and 3 only
- D 2 and 3 only

47 Which of the following is an example of diffusion in a plant?

- A Water in xylem moving from roots to leaves.
- B Sugars in phloem moving from leaves to roots.
- C Ions moving into root hairs against a concentration gradient.
- D Carbon dioxide from the air moving into a photosynthesising leaf.

MOVEMENT OF SUBSTANCES STRUCTURED QUESTIONS

1 Fig. 3.1 shows a plant which grows in well-watered soil in the shade.

Plants are usually dug up and transplanted with its roots and the surrounding soil.

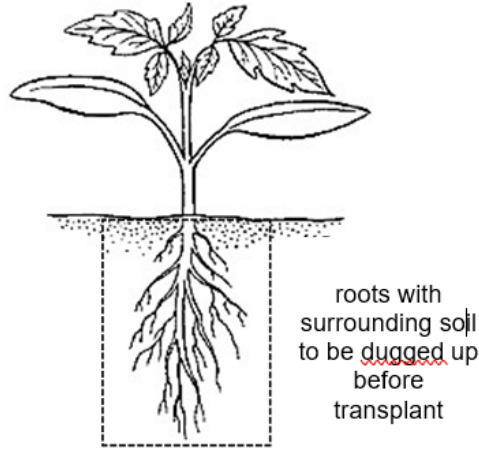

Fig 3.1

An unskilled farmer pulled the plant by its stem directly from the ground before being transplanted in another area of well-watered soil in the shade.

(a) Suggest and explain why the plant wilted for the first several days after being transplanted by the unskilled farmer.

.....
.....
.....
.....[2]

(b) (i) Potassium ions are mineral salts important for protein synthesis.

Describe the processes involved in the uptake of potassium ions from the soil and the pathway it takes to reach the leaves of the plant.

.....
.....
.....
.....
.....
.....[3]

(ii) The roots of the plant can take in oxygen from the air spaces between the soil particles. In a waterlogged soil condition, excessive amount of water expels air from the spaces between the soil particles.

Explain how the rate of potassium ion uptake by the roots will be affected in a waterlogged soil condition.

.....
.....
.....
.....
.....[2]

Fig. 3.2 shows the outline of a root hair cell.

(c) Complete the root hair cell of a plant which has not been watered for several days in the space below.

Label only the cell wall, cell membrane and the cytoplasm. [2]

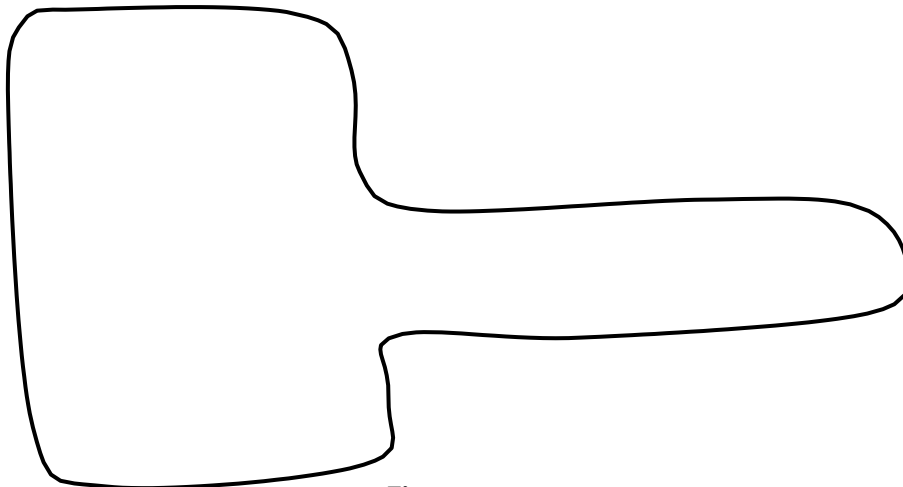

Fig. 3.2

(d) Describe an example of active transport in the human body.

.....

.....

.....

.....

.....

.....

.....

.....

.....

.....

.....

[2]

[Total: 10]

3 A group of students investigated the effect of sucrose concentration on the change in length of cylinders of tissue cut from a young carrot. They measured the initial lengths of the carrot cylinders, and then placed one in each of the different sucrose solutions.

After 18 hours, they removed the carrot cylinders and measured their final lengths. Some of the results are shown in Table 2.1.

Table 2.1

sucrose concentration / mol per dm ³	percentage change in length of carrot cylinders / %
0.4	+ 10.0
0.5	+ 6.4
0.6	+ 3.5
0.7	- 1.8
0.8	- 5.3
0.9	- 9.7
1.0	-13.3

(a) Explain why there is a change in length of the carrot cylinders when they are immersed in 0.5 mol/dm³ sucrose concentration.

.....

.....

.....

.....

.....

.....

.....

.....

.....

.....

.....

[2]

(b) Describe how you would use a graph to predict the cell sap concentration of the carrot.

.....
.....
.....
..... [2]

(c) Young carrots store sugars in their tissues, but in older carrots, some of this is converted to starch.

Explain how using cylinders from older carrots would affect the results obtained when the cylinders are placed in a 1.0 mol/dm³ sucrose solution.

.....
.....
.....
..... [3]

4 Some vegetables are not drought resistant. Harvests decrease considerably after short periods of water deficiency due to osmotic effect. Knowing the moisture content or water potential in vegetable tissues helps the farmers to moderate and control the level of moisture stress on their crops.

In this experiment you are going to investigate the process of osmosis across a Visking tubing containing 30% sucrose solution which simulates the content of the plant tissues.

You are provided with a Visking tubing (tied at one end), a beaker of 30% sucrose solution and a measuring cylinder (50 cm³).

- Step 1 Fill the measuring cylinder with about 30 cm³ of water.
- Step 2 Remove the Visking tubing from the container and squeeze out any water which may be inside.
- Step 3 Wipe the outer part of the Visking tubing dry.
- Step 4 Use a syringe provided to fill the Visking tubing with 10 cm³ of sucrose solution.
- Step 5 Wipe the exterior of the Visking tubing dry.

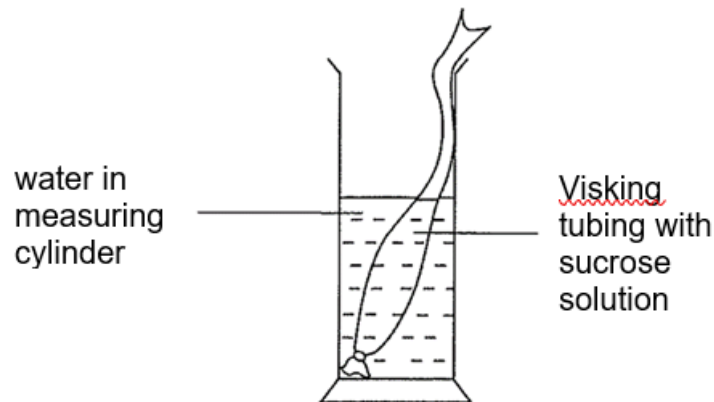

- Step 6 Lower the Visking tubing into the water in the measuring cylinder. Ensure that the portion of the tubing with the sucrose solution is fully submerged in the water.
- Step 7 Raise the whole Visking tubing above the water and record the volume of the water in the measuring cylinder.
- Step 8 Lower the Visking tubing back into the measuring cylinder.
- Step 9 Start the stopwatch.
- Step 10 Repeat steps 7 and 8 at 5 minutes interval for a duration of 30 minutes.
- Step 11 Present your results appropriately in a table format in **1(a)(i)**.

(a) (i) Record your results in a table in the space provided.

(ii) Plot a graph with your results on the grid provided below.

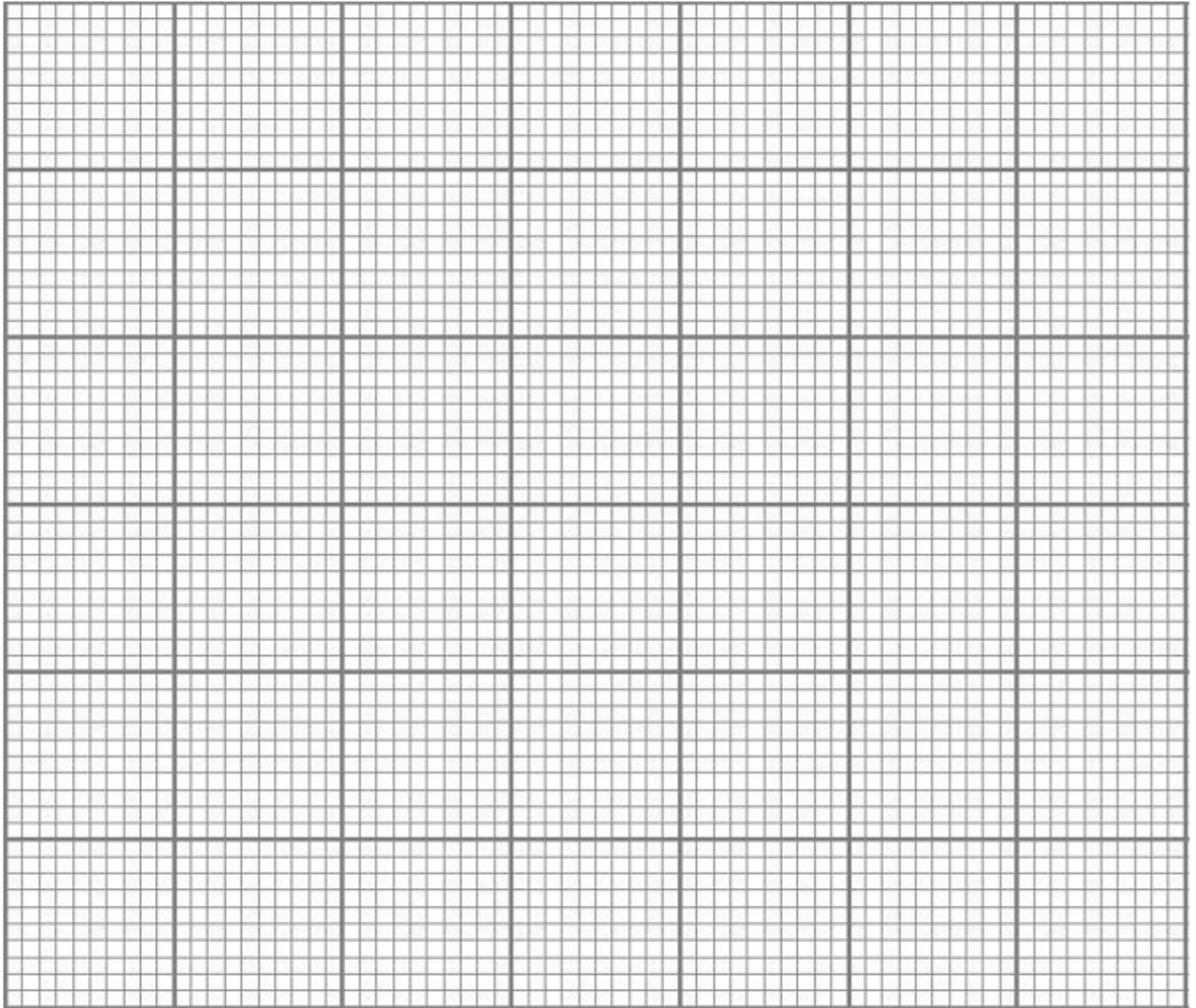

[4]

(iii) If the concentration of the sucrose solution were increased from 30% to 50%, predict the result obtained from 50% sucrose solution by sketching a line (label it **50%**) on the graph you have plotted in **1a(ii)**. [1]

(iv) Comment on the trend of the graph plotted and suggest a reason for the results.

.....
.....
.....
..... [2]

(v) Identify one key source of experimental error and explain how it affects the results.

.....
.....
.....
..... [2]

(vi) Suggest two improvements to this experiment to obtain a more reliable result.

.....
.....
.....
..... [2]

(b) Food nutrients can be classified into fats, protein and carbohydrate. You are given a food nutrient, **sample X**. It is different from the class of food which sucrose belongs to.

(i) Conduct a food test, using only the test reagents given, to identify the food class which sample **X** belongs to. Write the procedure of the food test below.

.....
.....
.....
..... [2]

(ii) Record all your data in a suitable format in the space below.

[3]

[Total: 20]

5 You are required to investigate the effect of sucrose concentration on osmosis across cell membranes in Chinese leek.

You are provided with the following:

- 4 long Chinese leek
- 0.2 moldm^{-3} of sucrose solution
- 0.4 moldm^{-3} of sucrose solution
- 0.6 moldm^{-3} of sucrose solution
- 0.8 moldm^{-3} of sucrose solution
- scalpel
- white tile
- stopwatch
- one 15 cm ruler
- safety goggles
- 8 cm^3 plasticine
- four petri dishes
- marker pen
- one A4 sheet of graph paper

In this investigation, you will record the effect of sucrose concentration on osmosis in Chinese leek and estimate the concentration of the cell sap by analysing the plotted graph of collected data.

Proceed as follows:

- Step 1 Using a sharp scalpel, cut a 5 cm long piece of Chinese leek stalk from the centre portion of the specimen provided.
- Step 2 Cut the 5 cm long stem longitudinally downwards for a length of approximately 4 cm (see Fig. 1.1). **Do not cut all the way through.**

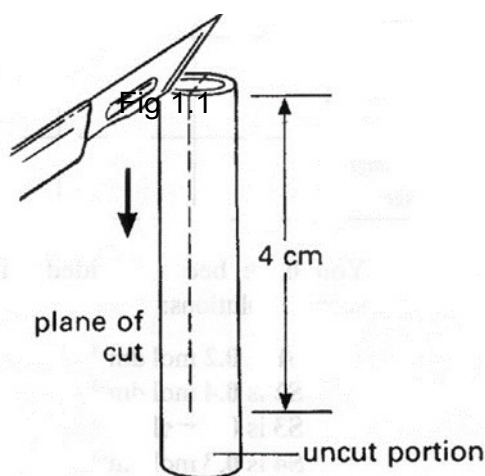

Step 3 You should find that the specimen has curved, as shown in Fig. 1.2.

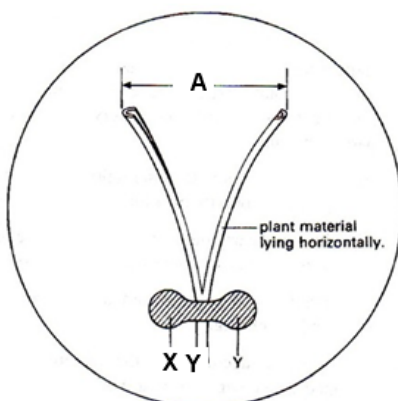

Fig. 1.2

Step 4 Check that the initial distance, **A**, between the cut portions is at least 1 cm.

Step 5 Lay the piece of plant tissue horizontally on the base of a clean, dry Petri dish.

Step 6 Taking care not to squash the plant material, gently but firmly fix it to the dish using a small roll of plasticine, which you press down at **X** and **Y** (see Fig 1.2).

Step 7 Repeat steps 1 to 6 to prepare three more dishes with three other 5 cm long Chinese leek stalks.

Step 8 Label your dishes **1, 2, 3** and **4**

Step 9 Place the four dishes on the sheet of graph paper provided and measure (to the nearest mm), the initial distance **A** of the Chinese leek stalk in each dish. **Record these distances in (b) on page 4.**

Step 10 Gently pour the **0.2 mol dm⁻³** sucrose solution into dish **1** until the piece of plant tissue is **completely submerged** in the solution.

(a) Explain the rationale for Step 10

.....

.....

..... [2]

Step 11 Repeat step 10 for dish **2** (0.4 moldm⁻³), dish **3** (0.6 moldm⁻³) and dish **4** (0.8 moldm⁻³) as quickly as possible and start the stopwatch.

Step 12 Leave the dishes for 10 minutes.

Step 13 After 10 minutes, measure (to the nearest mm) the final distance **A** in each of the dishes. **Record these measurements in (b) below.**

Step 14 For each dish, calculate the change in distance **A** and calculate the percentage change in **A** as follows:

Step 15 **Record your calculations in (b)** and state if the value is positive or negative.

(b) Record all your results in an appropriate table with the following headings and corresponding units: concentration of solution in dish; initial distance **A**; final distance of **A** after 10 min; change in distance **A**; percentage change in distance **A**, in the space below.

(c) Describe two significant sources of error in this experiment.

(i)

.....
 [1]

(ii)

.....
 [1]

(d) Explain how improvements can be made to the experiment to address the sources of error in (c).

(i)

.....
 [1]

(ii)

.....
 [1]

(e) A student performed the experiment by measuring mass instead and obtain the results tabulated in Table 1.1. Process the tabulated data within Table 1.1 below.

[2]

Table 1.1

concentration of sucrose solution in dish / mol dm ⁻³	initial mass of tissue / g	final mass of tissue after 10 mins / g	change in mass of tissue / g	percentage change in mass of tissue / %
0.2	1.0	1.3		
0.4	1.0	1.0		
0.6	0.6	0.4		
0.8	0.8	0.4		

- (f) Plot a graph based on the student's results in Table 1.1.

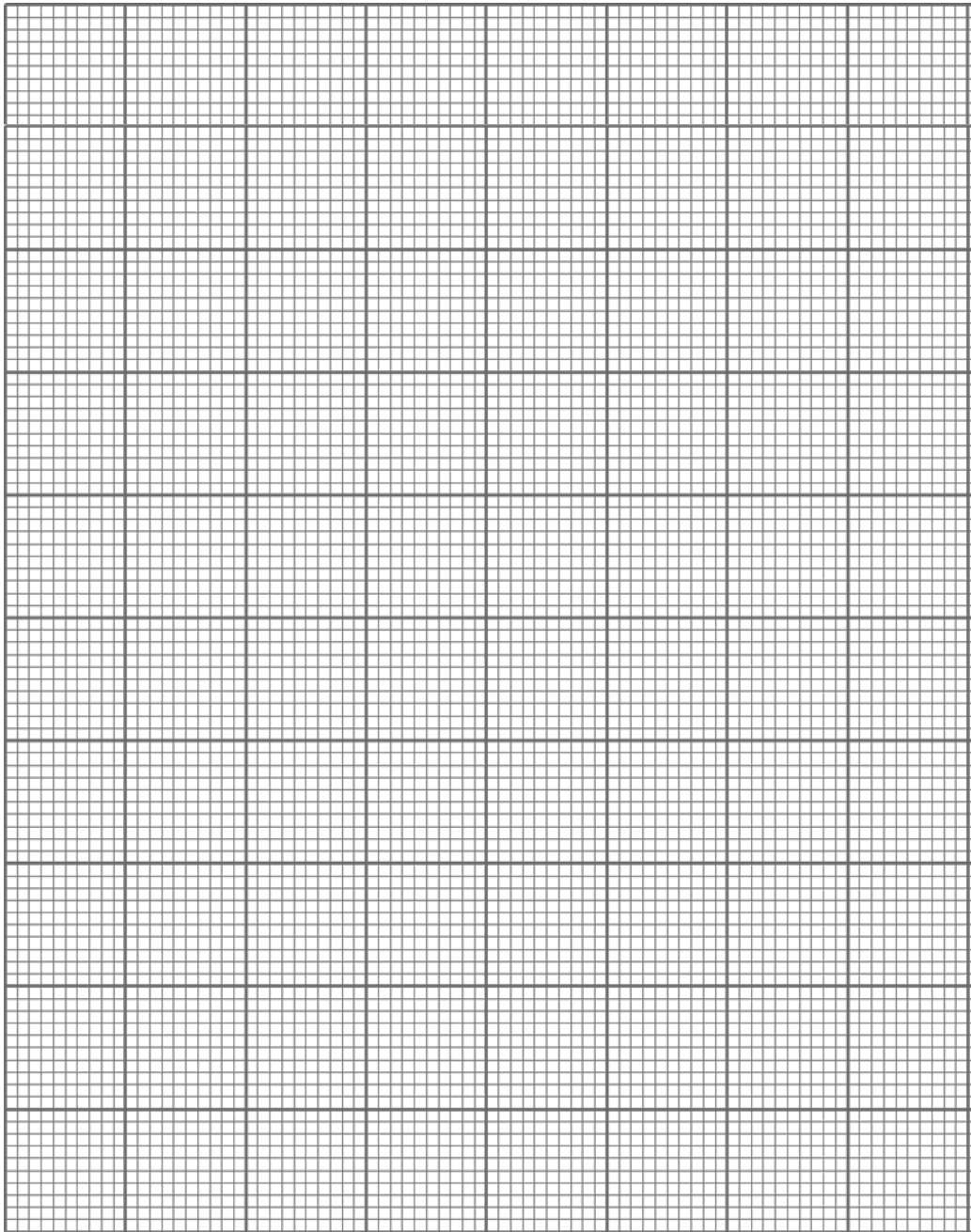

[4]

(g) With reference to the graph plotted,

(i) explain the shape of the graph.

.....
.....
.....
.....
.....
.....
.....
.....
..... [4]

(ii) explain how the concentration of the cell sap in the Chinese leek can be estimated.

.....
.....
..... [1]

[Total: 21 marks]

- 6 A group of students investigated the effect of sucrose concentration on the change in length of cylinders of tissue cut from a young carrot. They measured the initial lengths of the carrot cylinders, and then placed one in each of the different sucrose solutions. After 18 hours, they removed the carrot cylinders and measured their final lengths. Some of the results are shown in Table 2.1.

Table 2.1

sucrose concentration mol / dm ³	% decrease in length of carrot cylinders
0.4	4.2
0.5	8.7
0.6	13.0
0.7	16.8
0.8	18.0
0.9	18.0
1.0	18.0

- (a) Explain why there is a decrease in length of the carrot cylinders when they are immersed in 0.5 mol / dm³ sucrose solution of concentration.

.....
.....
..... [3]

- (b) Describe how you would use a graph to predict the cell sap concentration of the carrot.

.....
.....
..... [2]

- (c) Young carrots store sugars in their tissues but, in older carrots, some of this is converted to starch.

Explain how using cylinders from older carrots would affect the results obtained when the cylinders are placed in a 0.6 mol / dm³ sucrose solution?

.....
.....
.....
..... [3]

[Total: 8]

- 7 A student carried out an investigation using red blood cells.

The red blood cells were placed in sugar solutions at five different concentrations for 10 minutes. For each concentration, a sample was added immediately to a microscope slide and the cells were viewed using a light microscope. The observations recorded are shown in Table 1.1.

Table 1.1

concentration of sugar solution / %	observation of red blood cells
0.0	
0.4	increased in size
0.9	remains same size
1.5	decreased in size
3.0	decreased in size, spikes formed

- (a) Complete Table 1.1 to show the observation of red blood cells in the 0.0% sugar solution. [1]
- (b) Explain the observation of red blood cells in 0.0% sugar solution, as stated in part (a).

.....

.....

.....

.....

.....

..... [3]

- (c) Using the information in Table 1.1, predict the water potential of the red blood cells, and explain your answer.

.....
.....
.....
.....

[2]

- (d) The red blood cell is just one of many types of specialized cells in the human body. The cells found in the alimentary canal are also well adapted for their functions.

Describe and explain how cells in the small intestine are adapted for the uptake of glucose.

.....
.....
.....
..... [2]

[Total: 8]

- 8 Paramecium is a fresh water organism that has contractile vacuoles that are filled with water from the surrounding and expels water when the vacuoles contract.

Fig. 22.1 shows the image of Paramecium.



Fig. 22.1

Paramecium is placed in different concentrations of salt solution and the number of contractions shown by *Paramecium* in one minute is counted. The experiment is conducted in triplicates and the average number of contractions counted in one minute is recorded in Table 22.1.

Table 22.1

Concentration of salt solution/ mol dm ⁻³	average number of contractions counted in one minute
0.00	105
0.20	98
0.50	62
0.70	45

(a) State and explain how water enters *Paramecium*.

.....
.....
.....
.....
.....
.....[3]

(b) Describe and explain the results shown in Table 22.1.

.....
.....
.....
.....
.....
.....[4]

[Total :7]

- 9 An investigation on the relationship between surface area to volume ratio and rate of diffusion of a colour solution in agar cubes was carried out in the laboratory. The results of investigation are shown in Table 7.1.

Table 7.1

Surface area/ volume ratio of agar	Time taken to change colour of agar/s
1.5	120
2	105
3	84
4	60
6	30

- (a) Draw a graph to show the relationship of surface area to volume ratio and time taken for agar cubes to change colour.

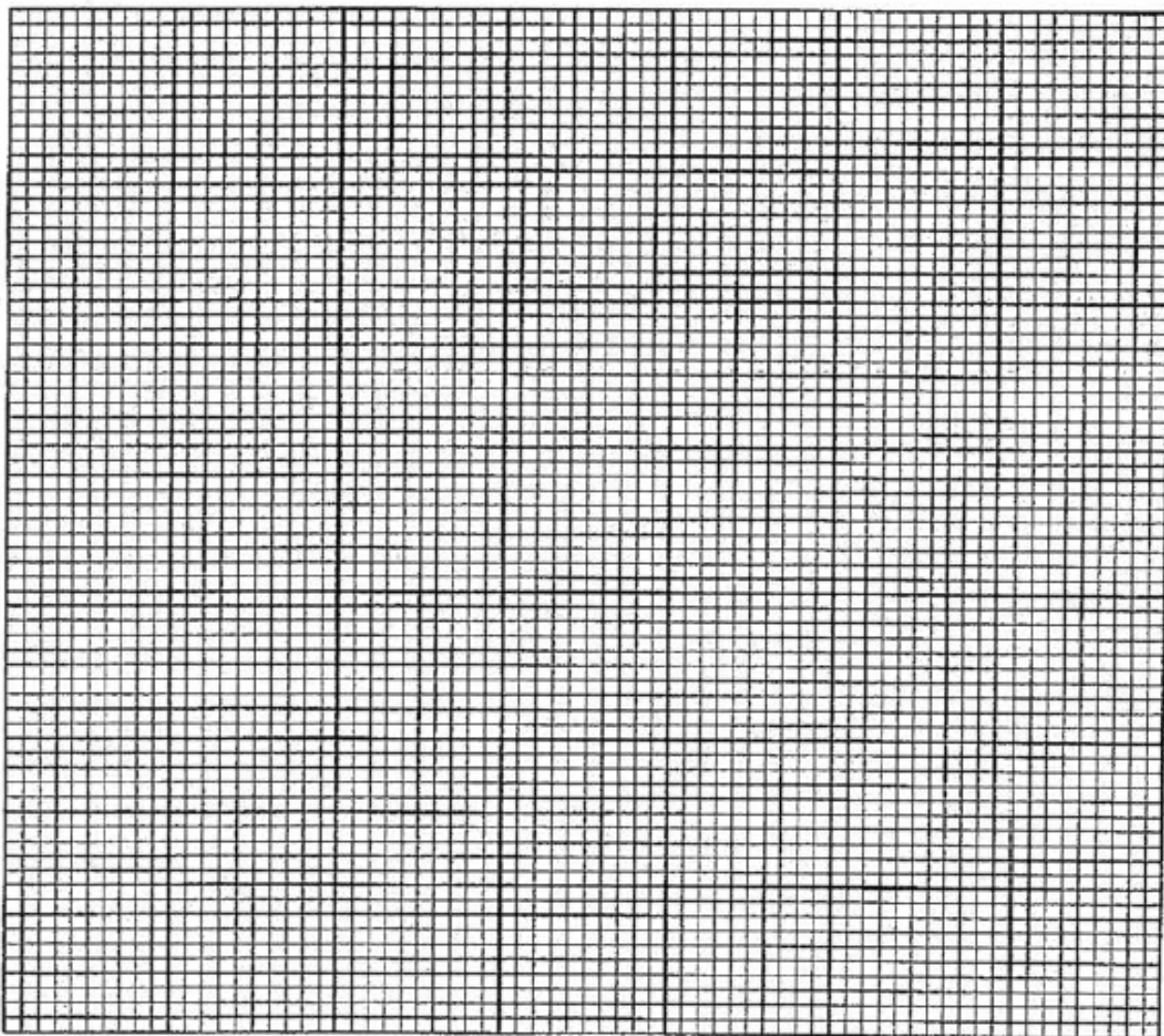

(b) From the graph, describe the relationship between surface area to volume ratio and the diffusion rate of the agar cubes.

.....
.....[1]

(c) Suggest two possible sources or error which may have affected the results of the investigation

.....
.....
.....
.....
.....
.....
.....
.....
.....[2]

10 Fig. 2.1 shows an experimental set up involving a yam tuber. A cavity was bored into a freshly peeled yam tuber. The cavity is filled with concentrated sucrose solution before immersing the yam tuber into a beaker of dilute sucrose solution.

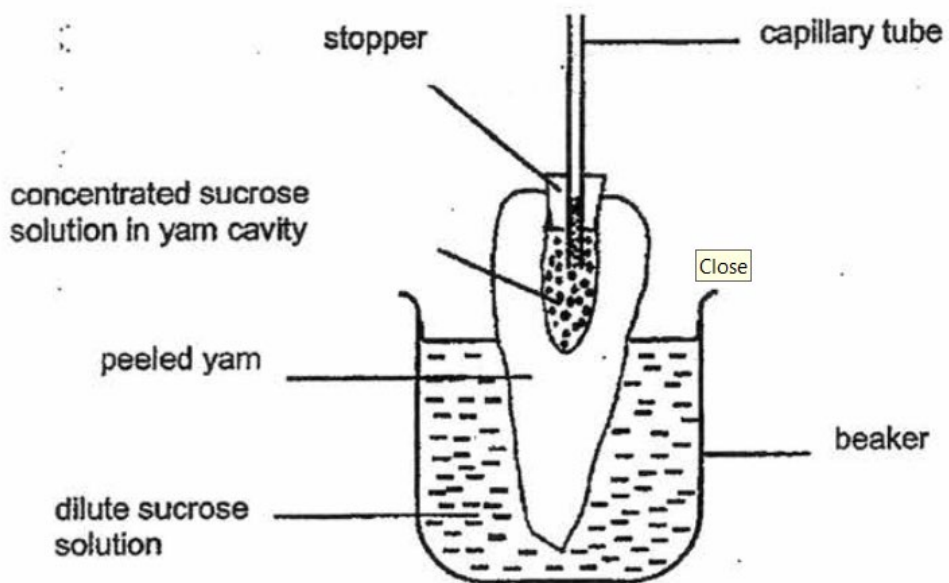

Fig. 2.1

(a) State what happened to the level of the concentrated sucrose solution in the capillary tube after thirty minutes. Explain your answer.

.....
.....
.....
.....[3]

(b) Suggest why the yam was peeled.

.....
.....[2]

(c) Predict what would happen to the liquid level in the capillary tube if the dilute sucrose solution was replaced with distilled water.

.....
.....[1]

11 Fig. 2.1 shows two chips that were cut from the same yam. They were blotted dry and weighed. They both had the same mass of 60 g.

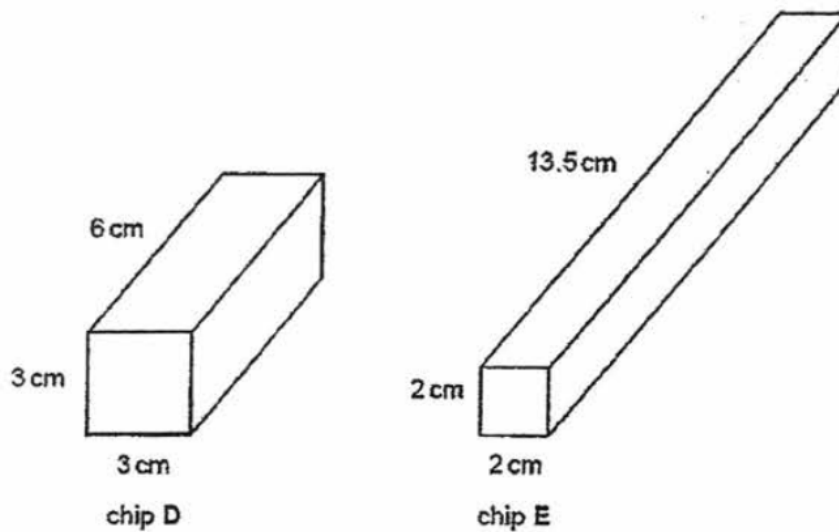

Fig. 2.1

Name the chemical that gives the cells their red colour. [1]

.....

(d) A student extracted some of these cells and placed them on a slide in distilled water. After three minutes the student looked at the slide using a microscope. No cells were visible, but the surrounding liquid was coloured pink.

(i) Deduce what had occurred to the cells during the three-minute period;

.....
..... [1]

(ii) Explain how the human body is able to prevent such an occurrence..

.....
.....
.....
..... [2]

Total: [9]

12 Six strips of potato tissue, each 5.0 cm long, were obtained from a potato. Three strips were placed in water and another three were placed in 25% sugar solution.

After 1 hour, the cylinders were removed from the solutions, blotted dry and outlined onto graph paper as shown below.

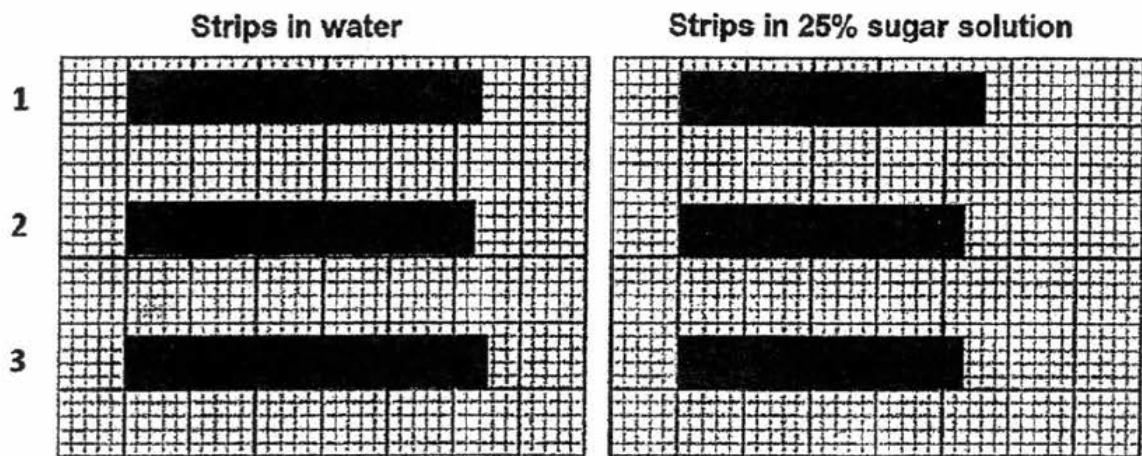

- (a) Record the new lengths of the strips (in 25% sugar solution) in the table below, then calculate the average length of the strips. [2]

Cylinder	Length of strip in water / cm	Length of strip in 25% sugar solution / cm
1	5.4	
2	5.3	
3	5.5	
Average length		

- (a) Explain why the strips change in length in (i) water [2]

- (ii) 25% sugar solution [2]

- (c) Which other measurements could have been taken to show that the strips had changed during the experiment? [1]

Total: 7m

- 13 Young vegetables like cucumber can be preserved for a long time by soaking them in brine (salt solution) as shown in Fig. 1.1. This soaking process removes moisture from the plant tissue and gives the cucumber a salty taste after the process.



Fig. 1.1

- (a) Explain how moisture is lost and a salty taste is acquired in the cucumber.

.....
.....
.....
.....
.....
.....[2]

- (b) State the term that describes the condition of plant tissues in this state.

.....[1]

(c) Fig. 1.2 shows how a cell of the cucumber looks like before the soaking process.

In the box below Fig 1.2, draw how the cell looks like after the soaking.

(Your answer should include labels for cell membrane, tonoplast)



Fig. 1.2: Cell *before* soaking in brine

Drawing of cell after soaking in brine

A large, empty rectangular box intended for the student to draw the cell after it has been soaked in brine. The box is defined by a thin black border.

ANSWERS FOR MOVEMENT OF SUBSTANCES MCQ

Q1: A	Q11: D	Q21: B	Q31: C	Q41: A
Q2: B	Q12: C	Q22: D	Q32: B	Q42: B
Q3: B	Q13: D	Q23: D	Q33: D	Q43: D
Q4: B	Q14: C	Q24: B	Q34: C	Q44: B
Q5: B	Q15: C	Q25: D	Q35: B	Q45: D
Q6: B	Q16: B	Q26: B	Q36: B	Q46: D
Q7: B	Q17: B	Q27: B	Q37: A	Q47: D
Q8: B	Q18: D	Q28: B	Q38: C	
Q9: B	Q19: D	Q29: C	Q39: D	
Q10: B	Q20: A	Q30: C	Q40: C	

ANSWERS FOR MOVEMENT OF SUBSTANCES STRUCTURED QUESTIONS

- 1 Fig. 3.1 shows a plant which grows in well-watered soil in the shade.

Plants are usually dug up and transplanted with its roots and the surrounding soil.

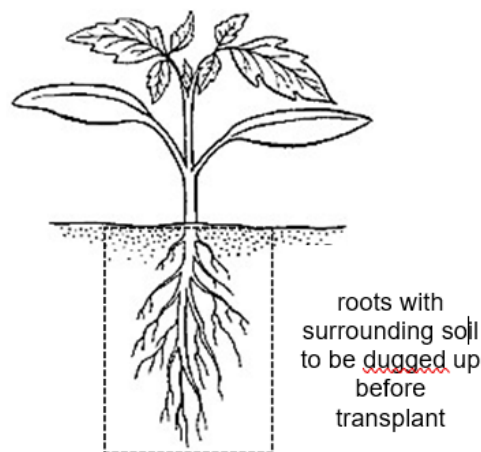

Fig 3.1

An unskilled farmer pulled the plant by its stem directly from the ground before being transplanted in another area of well-watered soil in the shade.

- (a) Suggest and explain why the plant wilted for the first several days after being transplanted by the unskilled farmer.

The roots were damaged/ xylem vessels are broken/ roots break off; hence rate of water loss is greater than water uptake/ cells become flaccid/ lose turgor pressure and wilt; [2]

- (b) (i) Potassium ions are mineral salts important for protein synthesis.

Describe the processes involved in the uptake of potassium ions from the soil and the pathway it takes to reach the leaves of the plant.

Uptake by diffusion/ active transport from soil into the root hair cell;
Diffuse into the inner cortical cells and reaches the xylem;
Transported by the xylem and into the leaf cells via diffusion; or
Via transpiration pull up to the leaves (max 3 marks) [3]

- (ii) The roots of the plant can take in oxygen from the air spaces between the soil particles. In a waterlogged soil condition, excessive amount of water expels air from the spaces between the soil particles.

Explain how the rate of potassium ion uptake by the roots will be affected in a waterlogged soil condition.

Rate decreases/ Reduce the rate of potassium ion uptake;
Less oxygen for respiration/ release energy for active transport. [2]

Fig. 3.2 shows the outline of a root hair cell.

- (c) Complete the root hair cell of a plant which has not been watered for several days in the space below.

Label all three parts correctly and clearly (Reject: non-plasmolysed version.)
Diagram: Plasmolysis- shows cell membrane tear away from cell wall.

Label only the cell wall, cell membrane and the cytoplasm. [2]

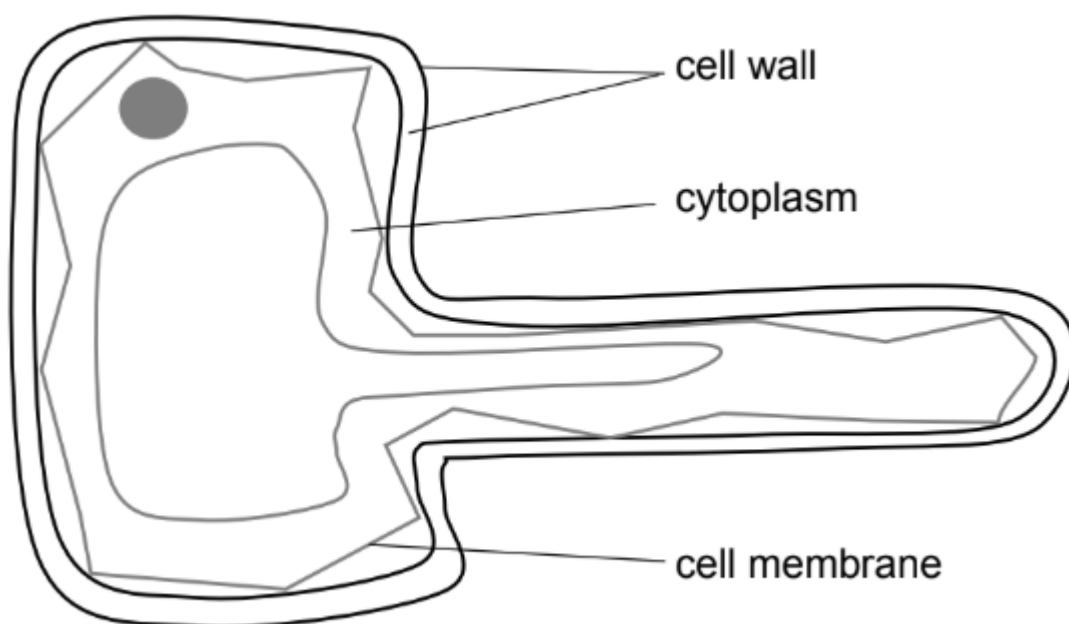

2 Diffusion and active transport occur in many living organisms.

(a) State two differences between diffusion and active transport.

difference in both diffusion and active transport must be described to be awarded 1 mark

diffusion	active transport
net movement of particles down concentration gradient	net movement of particles against concentration gradient
passive process / no energy expended;	energy expended; (R: active)
need not occur across a membrane;	occurs across a partially permeable / live membrane;

[2]

(b) Name the organelle that will be present in greater amounts in a cell that carries out active transport constantly. Explain the importance of this organelle.

mitochondria;
carries out aerobic respiration to release energy required by active transport;

[2]

(c) Fig. 9.1 shows an outline of a root hair cell.

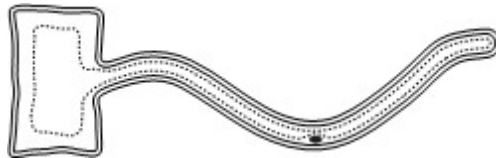

Explain why active transport is important for the function of root hair cells.

when the solution in the soil has a lower water potential than the root hair cell sap;
root hair absorbs mineral salts from the soil by active transport; lowering the water potential in the root hair cell sap; so that water can enter the root hair; by osmosis;

[4]

(d) Describe an example of active transport in the human body.

in the villi of the small intestine; [R: microvilli]
when the concentration of nutrients (or named) in the small intestine is low;
epithelial cells absorb nutrients by active transport;

[2]

[Total: 10]

- 3 A group of students investigated the effect of sucrose concentration on the change in length of cylinders of tissue cut from a young carrot. They measured the initial lengths of the carrot cylinders, and then placed one in each of the different sucrose solutions.

After 18 hours, they removed the carrot cylinders and measured their final lengths. Some of the results are shown in Table 2.1.

Table 2.1

sucrose concentration / mol per dm ³	percentage change in length of carrot cylinders / %
0.4	+ 10.0
0.5	+ 6.4
0.6	+ 3.5
0.7	- 1.8
0.8	- 5.3
0.9	- 9.7
1.0	-13.3

- (a) Explain why there is a change in length of the carrot cylinders when they are immersed in 0.5 mol/dm³ sucrose concentration.

Sucrose concentration 0.5 mol/dm³ has a higher water potential than the carrot cylinders;
 There is a net movement of water molecules from the sucrose solution into the carrot cells via osmosis across a partially permeable membrane. Hence, there is an increase in length;

[2]

- (b) Describe how you would use a graph to predict the cell sap concentration of the carrot.

Draw a graph of (percentage) change in length of carrot cylinders against sucrose concentration ;
 Find the point where the graph intersects/crosses the x-axis and this would be the concentration of the cell sap of the carrot;
 A: x-axis – concentration of sucrose + y-axis: (percentage) change in length/ increase or decrease in length

A: point where graph touches the x-axis / point where change is zero is the concentration of cell sap

[2]

- (c) Young carrots store sugars in their tissues, but in older carrots, some of this is converted to starch.
Explain how using cylinders from older carrots would affect the results obtained when the cylinders are placed in a 1.0 mol/dm^3 sucrose solution.

- There would be a greater decrease in length of the carrot;
- Starch is insoluble in water / would not affect water potential of the cell ;

OR

The concentration of sugar in old carrots is lower than young carrots. Hence, they have higher water potential as compared to young carrots;

- There will be more water molecules moving out of the carrot cell via osmosis;

Reject:

- % change in length of an older carrot would be smaller

(This means the change in length for older carrots is less than that of younger carrots)

- Starch is a large molecule and cannot leave the cell (this does not explain why water potential of cell is not affected.

Water potential is only affected if molecules are SOLUBLE.)

[3]

- 4 Some vegetables are not drought resistant. Harvests decrease considerably after short periods of water deficiency due to osmotic effect. Knowing the moisture content or water potential in vegetable tissues helps the farmers to moderate and control the level of moisture stress on their crops.

In this experiment you are going to investigate the process of osmosis across a Visking tubing containing 30% sucrose solution which simulates the content of the plant tissues.

You are provided with a Visking tubing (tied at one end), a beaker of 30% sucrose solution and a measuring cylinder (50 cm^3).

- Step 1 Fill the measuring cylinder with about 30 cm^3 of water.
- Step 2 Remove the Visking tubing from the container and squeeze out any water which may be inside.
- Step 3 Wipe the outer part of the Visking tubing dry.
- Step 4 Use a syringe provided to fill the Visking tubing with 10 cm^3 of sucrose solution.
- Step 5 Wipe the exterior of the Visking tubing dry.

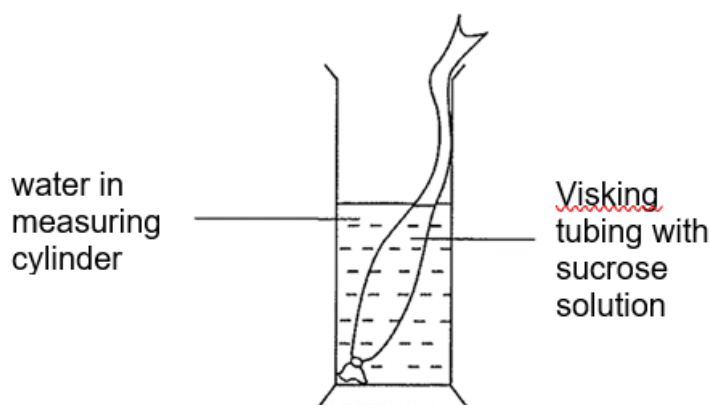

- Step 6 Lower the Visking tubing into the water in the measuring cylinder. Ensure that the portion of the tubing with the sucrose solution is fully submerged in the water.
- Step 7 Raise the whole Visking tubing above the water and record the volume of the water in the measuring cylinder.
- Step 8 Lower the Visking tubing back into the measuring cylinder.
- Step 9 Start the stopwatch.
- Step 10 Repeat steps 7 and 8 at 5 minutes interval for a duration of 30 minutes.
- Step 11 Present your results appropriately in a table format in **1(a)(i)**.

(a) (i) Record your results in a table in the space provided.

MMO / PDO

- 1. Table with correct headings and correct units;
- 2. Record time and volume of water in measuring cylinder at 5 minutes interval. (7 sets of readings from t=0 min to t=30 min);
- 3. Correct precision (nearest mm or 1 decimal place for cm);
- 4. Accuracy: reading follow the same trend as teacher's results;

Time /min	Volume of sucrose /cm ³
0	30.0
5	29.5
10	29.0
15	28.5
20	28.0
25	27.5
30	27.0

[4]

(ii) Plot a graph with your results on the grid provided below.

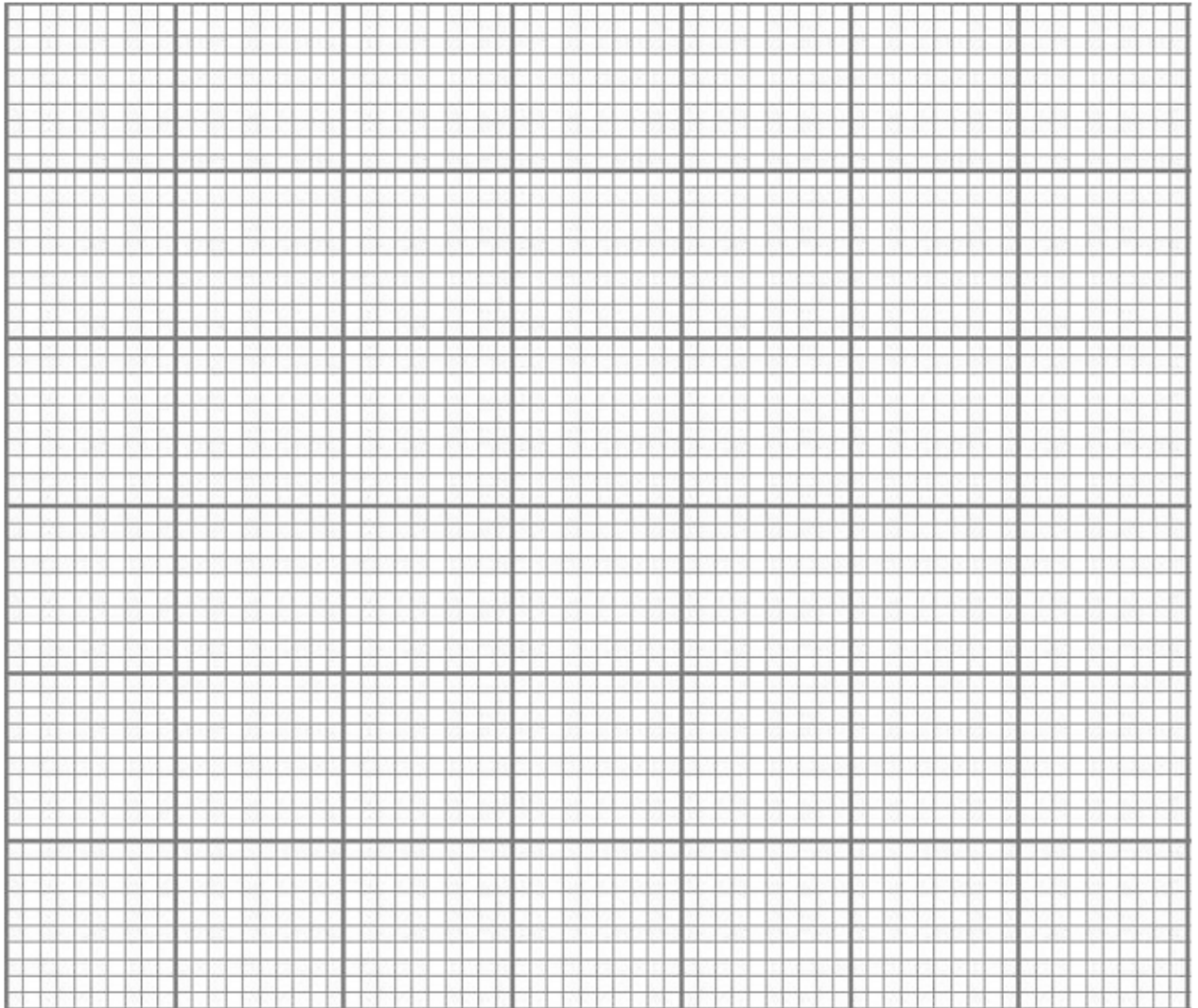
**PDO**

1. axes correctly orientated and fully labelled with units;
2. all plots clear and correct ;
3. Best-fit: smooth curve cleanly drawn through most plots or plots neatly joined by ruled lines ;
4. regular scale and good size;

[4]

(iii) If the concentration of the sucrose solution were increased from 30% to 50%, predict the result obtained from 50% sucrose solution by sketching a line (label it **50%**) on the graph you have plotted in **1a(ii)**. [1]

PDO

Sketch a graph below + steeper than the plotted graph for **(a)(ii)**, to indicate faster rate of diffusion of sucrose out of the Visking tubing.

- (iv) Comment on the trend of the graph plotted and suggest a reason for the results.

ACE

Osmosis causes water molecules to enter from measuring cylinder into Visking tubing resulting;

Resulting in decrease in water level in the measuring cylinder Water molecules move from higher water potential to sucrose solution with a lower water potential [2]

- (v) Identify one key source of experimental error and explain how it affects the results.

SOE: drops of water stick onto surface of Visking tubing when it is lifted up;

Effect: some water loss from the measuring cylinder/readings of water level is lower;

OR

SOE: amount of water sticking onto surface of Visking tubing varies each time tubing is lifted up;

Effect: some water loss from the measuring cylinder varies/readings of are inaccurate;

OR

SOE: interior of Visking tubing is wet when it is filled with sucrose solution;

Effect: sucrose solution is diluted leading to higher readings. [2]

- (vi) Suggest two improvements to this experiment to obtain a more reliable result.

Small intestines

[2]

blood capillaries/blood plasma in blood capillaries

- (b) Food nutrients can be classified into fats, protein and carbohydrate. You are given a food nutrient, **sample X**. It is different from the class of food which sucrose belongs to.

- (i) Conduct a food test, using only the test reagents given, to identify the food class which sample **X** belongs to. Write the procedure of the food test below.

MMO / PDO

Biuret test procedure description:

1. Add 2 cm³ of sodium hydroxide solution into sample x;

2. Add copper sulphate solution to the mixture in drops and shake; [2]

(ii) Record all your data in a suitable format in the space below.

Tabulation

1. Table is used as format for data recording;
2. With headings to include (food test/reagents used; observation; conclusion);
3. Accuracy of data: observation: purple/violet colour
4. Accuracy of data: conclusion of class for sample x is protein;

[3]

[Total: 20]

5 You are required to investigate the effect of sucrose concentration on osmosis across cell membranes in Chinese leek.

You are provided with the following:

- 4 long Chinese leek
- 0.2 moldm^{-3} of sucrose solution
- 0.4 moldm^{-3} of sucrose solution
- 0.6 moldm^{-3} of sucrose solution
- 0.8 moldm^{-3} of sucrose solution
- scalpel
- white tile
- stopwatch
- one 15 cm ruler
- safety goggles
- 8 cm^3 plasticine
- four petri dishes
- marker pen
- one A4 sheet of graph paper

In this investigation, you will record the effect of sucrose concentration on osmosis in Chinese leek and estimate the concentration of the cell sap by analysing the plotted graph of collected data.

Proceed as follows:

- Step 1 Using a sharp scalpel, cut a 5 cm long piece of Chinese leek stalk from the centre portion of the specimen provided.
- Step 2 Cut the 5 cm long stem longitudinally downwards for a length of approximately 4 cm (see Fig. 1.1). **Do not cut all the way through.**

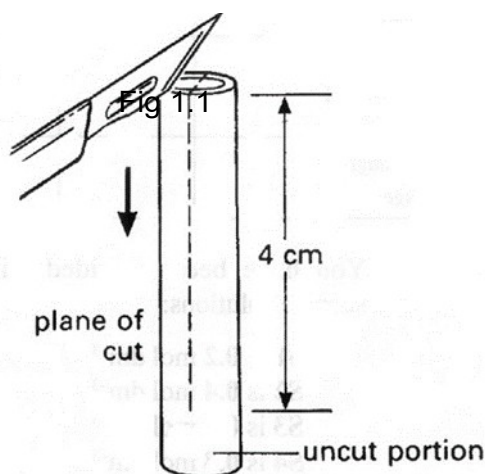

Step 3 You should find that the specimen has curved, as shown in Fig. 1.2.

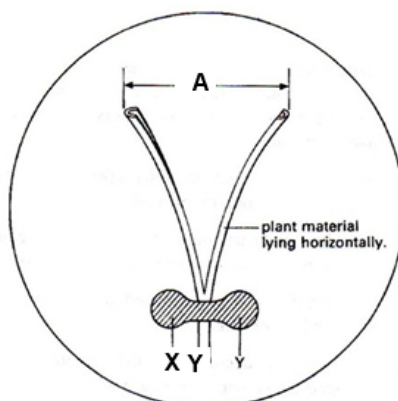

Fig. 1.2

Step 4 Check that the initial distance, **A**, between the cut portions is at least 1 cm.

Step 5 Lay the piece of plant tissue horizontally on the base of a clean, dry Petri dish.

Step 6 Taking care not to squash the plant material, gently but firmly fix it to the dish using a small roll of plasticine, which you press down at **X** and **Y** (see Fig 1.2).

Step 7 Repeat steps 1 to 6 to prepare three more dishes with three other 5 cm long Chinese leek stalks.

Step 8 Label your dishes **1**, **2**, **3** and **4**

Step 9 Place the four dishes on the sheet of graph paper provided and measure (to the nearest mm), the initial distance **A** of the Chinese leek stalk in each dish. **Record these distances in (b) on page 4.**

Step 10 Gently pour the **0.2 mol dm⁻³** sucrose solution into dish **1** until the piece of plant tissue is **completely submerged** in the solution.

(a) Explain the rationale for Step 10

- To ensure that plasticine hold the specimen to the base to prevent the specimen from floating;
- All parts of the specimen is exposed to the sucrose solution (OWTTE).

Reject: ref. to surface area to volume ratio (irrelevant)

[2]

Step 11 Repeat step 10 for dish **2** (0.4 moldm⁻³), dish **3** (0.6 moldm⁻³) and dish **4** (0.8 moldm⁻³) as quickly as possible and start the stopwatch.

Step 12 Leave the dishes for 10 minutes.

- Step 13 After 10 minutes, measure (to the nearest mm) the final distance **A** in each of the dishes. **Record these measurements in (b) below.**
- Step 14 For each dish, calculate the change in distance **A** and calculate the percentage change in **A** as follows:
- Step 15 **Record your calculations in (b)** and state if the value is positive or negative.

(b) Record all your results in an appropriate table with the following headings and corresponding units: concentration of solution in dish; initial distance **A**; final distance of **A** after 10 min; change in distance **A**; percentage change in distance **A**, in the space below.

- Headings (concentration of sucrose solution in the extreme left column; initial distance of A; final distance of A; change in distance of A; percentage change in distance of A).
- Units (Concentration of sucrose solution / mol dm^{-3} ; Initial distance of A / mm; Final distance of A / mm; Change in distance of A / mm; Percentage change in distance of A / %) found only in the headings; Concentration of sucrose solution arranged in ascending / descending order
- Accuracy in sucrose concentration (1 d.p.) and distance (1 d.p. for cm / whole no. for mm) and percentage (whole number), to the correct degree of precision.
- Indication of direction of change + / - in percentage change in distance of A

Note: Minus 1m if initial distance of A less than 1 cm.

(c) Describe two significant sources of error in this experiment.

Any two of the following points:

- Time delay in addition of the various sucrose solution result in non-uniform exposure time
- There was no **repeated experiment** for each concentration hence random errors **affect reliability of results**.
- Insufficient data points for analysis of result (at least 5 data points for accurate graph plot)
- **Accept other valid points**

(d) Explain how improvements can be made to the experiment to address the sources of error in (c).

Any two corresponding point to (d): ACE

- Stagger the addition of various sucrose solution to ensure uniform exposure time.
- Perform replicates per sucrose concentration and obtain average to minimize random errors.
- Have narrower and increase number of intervals between sucrose concentrations to ensure more accurate results.

(e) A student performed the experiment by measuring mass instead and obtain the results tabulated in Table 1.1. Process the tabulated data within Table 1.1 below. [2]

Table 1.1

concentration of sucrose solution in dish / mol dm ⁻³	initial mass of tissue / g	final mass of tissue after 10 mins / g	change in mass of tissue / g	percentage change in mass of tissue / %
0.2	1.0	1.3		
0.4	1.0	1.0		
0.6	0.6	0.4		
0.8	0.8	0.4		

- Correct computation of change in mass of tissue
- Correct computation of percentage change (whole number) and direction of change .

- (f) Plot a graph based on the student's results in Table 1.1.

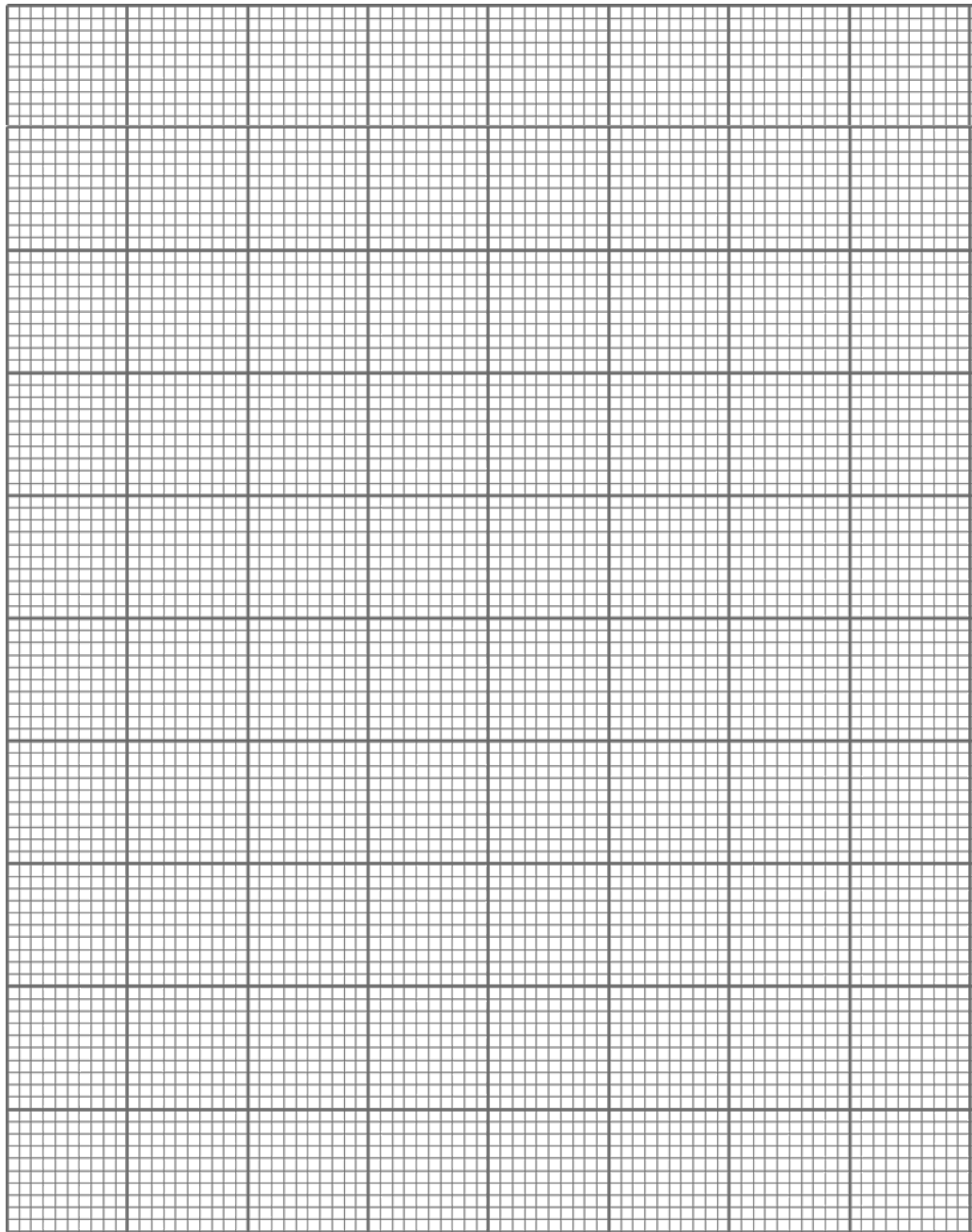

[4]

Points plotted correctly

- Axes labelled correctly with units (x-axis: concentration of sucrose solution / mol dm^{-3} ; y-axis: percentage change in mass / %)
- Line of best fit
- Appropriate scale used (occupies at least 1/2 the space)

(g) With reference to the graph plotted,

(i) explain the shape of the graph.

- [Trend] As sucrose concentration increases, the percentage changes in mass becomes more negative.

Reject: % change becomes smaller / decreases (without data citation) – unclear description of trend.

- At low sucrose concentration (lesser than 0.4 mol dm^{-3}), percentage change in mass is positive due to the movement of water molecules into the cells by osmosis from a region of higher water potential in the sucrose solution to lower water potential in the cell sap.

- At high sucrose concentration (0.4 mol dm^{-3} and above), percentage change in distance A is negative due to the movement of water molecules out of the cells by osmosis from a region of higher water potential in the cell sap to lower water potential in the sucrose solution.

- Increase / decrease in mass is a result of net movement of water molecules in / out of cell via osmosis across partially permeable membrane.

Note: Minus 1m for no reference to water molecules (only once).

[4]

(ii) explain how the concentration of the cell sap in the Chinese leek can be estimated.

- At the concentration of sucrose solution where there is no net movement of water as the water potential of the sucrose solution and in the cell sap is the same. This would be the concentration of the cell sap.

OR

- Point on graph/line that cuts X-axis + explanation

[1]

[Total: 21 marks]

- 6 A group of students investigated the effect of sucrose concentration on the change in length of cylinders of tissue cut from a young carrot. They measured the initial lengths of the carrot cylinders, and then placed one in each of the different sucrose solutions. After 18 hours, they removed the carrot cylinders and measured their final lengths. Some of the results are shown in Table 2.1.

Table 2.1

sucrose concentration mol / dm ³	% decrease in length of carrot cylinders
0.4	4.2
0.5	8.7
0.6	13.0
0.7	16.8
0.8	18.0
0.9	18.0
1.0	18.0

- (a) Explain why there is a decrease in length of the carrot cylinders when they are immersed in 0.5 mol / dm³ sucrose solution of concentration.

- sucrose solution of concentration 0.5 mol/dm³ has a lower water potential than the carrot cylinders [1]
- Hence water molecules moves out of the carrot cells into the sucrose solution by osmosis [1]
- Down the water potential gradient across the partially permeable membrane [1]

[3]

- (b) Describe how you would use a graph to predict the cell sap concentration of the carrot.

- Draw a graph : x axis - Concentration of sucrose mol / dm³, y-axis – percentage change in length of carrot cylinders [1]
- Find point where graph crosses x axis [1] [2]

- (c) Young carrots store sugars in their tissues but, in older carrots, some of this is converted to starch.

Explain how using cylinders from older carrots would affect the results obtained when the cylinders are placed in a 0.6 mol / dm³ sucrose solution?

- Result : There would be a greater decrease in length.[1]
- Reason: Starch is insoluble and so the concentration of sucrose decreases [1]
- There is a greater difference in water potential between potato cells and sucrose solution. Hence more water molecules moves out by osmosis. [1] [3]

[Total: 8]

- 7 A student carried out an investigation using red blood cells.

The red blood cells were placed in sugar solutions at five different concentrations for 10 minutes. For each concentration, a sample was added immediately to a microscope slide and the cells were viewed using a light microscope. The observations recorded are shown in Table 1.1.

Table 1.1

concentration of sugar solution / %	observation of red blood cells
0.0	
0.4	increased in size
0.9	remains same size
1.5	decreased in size
3.0	decreased in size, spikes formed

- (a) Complete Table 1.1 to show the observation of red blood cells in the 0.0% sugar solution.
- (b) Explain the observation of red blood cells in 0.0% sugar solution, as stated in part (a).

Cannot be seen / swell and burst [1]

1. The cytoplasm of the red blood cells has a lower water potential compared to the sugar solution
2. Water molecules move from the sugar solution into the cytoplasm via osmosis
3. Cell surface membrane is unable to withstand the additional pressure and bursts

A: no cell wall, unable to hold so much water] [3]

- (c) Using the information in Table 1.1, predict the water potential of the red blood cells, and explain your answer.

1. Water potential is 0.9% sugar solution
2. There is no change to the size of the red blood cell, indicating no net movement of water molecules

[2]

- (d) The red blood cell is just one of many types of specialized cells in the human body. The cells found in the alimentary canal are also well adapted for their functions.

Describe and explain how cells in the small intestine are adapted for the uptake of glucose.

1. Epithelial cells contain numerous microvilli
2. This increases the surface area to volume ratio, allowing glucose to be absorbed / taken in at a faster rate

A: Contain mitochondria; to release energy to perform active transport of glucose.

R: folds of the intestinal walls / villi / one cell thick epithelium/ well supplied with blood capillaries and lacteals

[2]

[Total: 8]

- 8 *Paramecium* is a fresh water organism that has contractile vacuoles that are filled with water from the surrounding and expels water when the vacuoles contract.

Fig. 22.1 shows the image of *Paramecium*.



Fig. 22.1

Paramecium is placed in different concentrations of salt solution and the number of contractions shown by *Paramecium* in one minute is counted. The experiment is conducted in triplicates and the average number of contractions counted in one minute is recorded in Table 22.1.

Table 22.1

Concentration of salt solution/ mol dm ⁻³	average number of contractions counted in one minute
0.00	105
0.20	98
0.50	62
0.70	45

- (a) State and explain how water enters *Paramecium*.

Surrounding solution has a higher water potential than the cell cytoplasm.

Water molecules enter the cell across a partially permeable membrane.

By osmosis; [3]

(b) Describe and explain the results shown in Table 22.1.

As the concentration of salt solution increases from 0.0 to 0.7 mol dm⁻³, average number of contractions counted in one-minute decreases from 105 to 45.;

As the concentration of salt solution increases, the water potential gradient between surrounding salt solution and cytoplasm decreases.

Less water enters the cytoplasm of Paramecium.

Fewer contractions occur to expel water out of Paramecium.; [4]

[Total :7]

- 9 An investigation on the relationship between surface area to volume ratio and rate of diffusion of a colour solution in agar cubes was carried out in the laboratory. The results of the investigation are shown in Table 7.1.

Table 7.1

Surface area/ volume ratio of agar	Time taken to change colour of agar/s
1.5	120
2	105
3	84
4	60
6	30

- (a) Draw a graph to show the relationship of surface area to volume ratio and time taken for agar cubes to change colour.

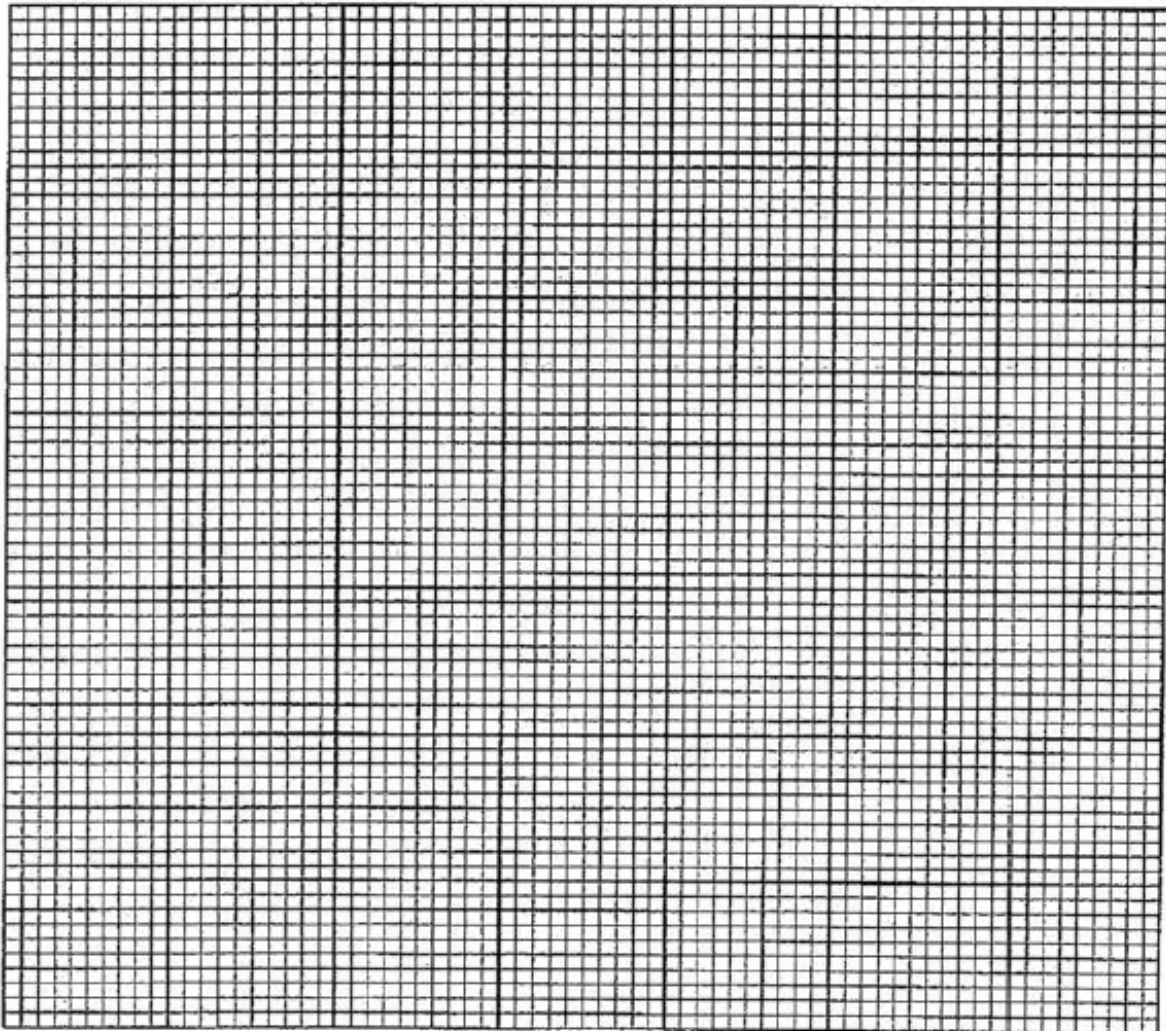

Correct scale;
 Correct axes labels'
 All points plotted correctly;
 Best fit line;
 Inverted axis (0 marks)

- (b) From the graph, describe the relationship between surface area to volume ratio and the diffusion rate of the agar cubes.

The bigger the SAW ratio, the shorter time / faster diffusion (rate) [1]

- (c) Suggest two possible sources or error which may have affected the results of the investigation

Determination of end point / point of colour change;

Variations in temperature;

Evaporation of solution, changing the concentration of the colour solution;

Not all surface area of agar exposed to the solution due to clumping/ WTTE.

[2]

- 10 Fig. 2.1 shows an experimental set up involving a yam tuber. A cavity was bored into a freshly peeled yam tuber. The cavity is filled with concentrated sucrose solution before immersing the yam tuber into a beaker of dilute sucrose solution.

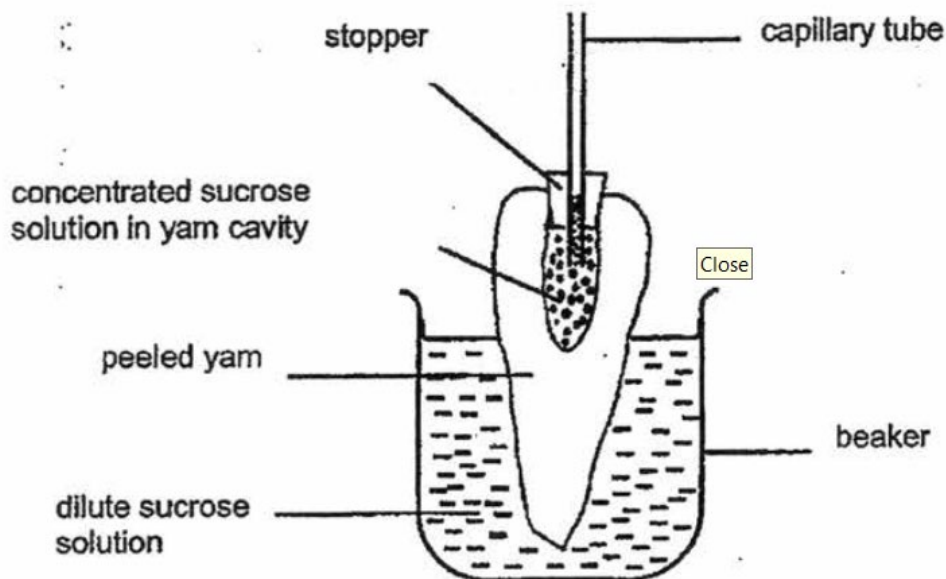

Fig. 2.1

- (a) State what happened to the level of the concentrated sucrose solution in the capillary tube after thirty minutes. Explain your answer.

It will rise [1]

The water potential in the cavity is lower than in the beaker [1]

Thus water moved from the beaker to cavity via osmosis [1]

[3]

- (b) Suggest why the yam was peeled.

The skin of the yam is impermeable [1]

Peeling exposes the yam membrane which is partially-permeable [1]

[2]

- (c) Predict what would happen to the liquid level in the capillary tube if the dilute sucrose solution was replaced with distilled water.

The liquid level will go higher

[1]

- 11 Fig. 2.1 shows two chips that were cut from the same yam. They were blotted dry and weighed. They both had the same mass of 60 g.

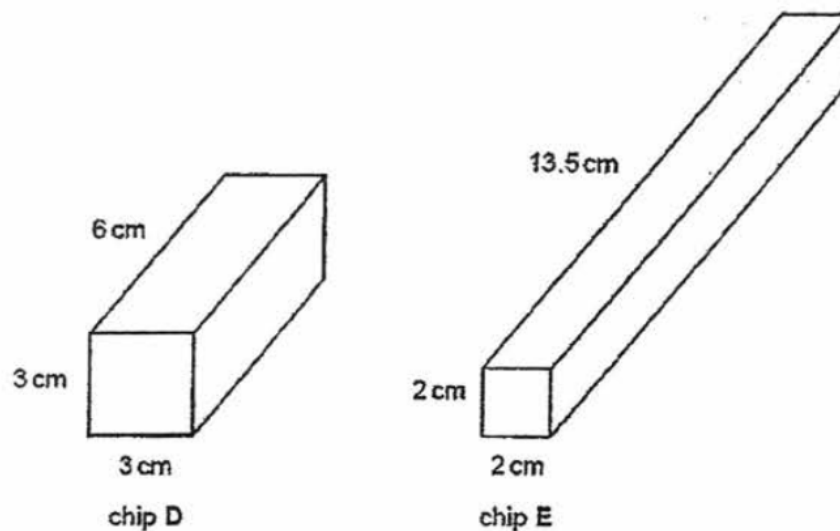

Fig. 2.1

Both chips were placed in distilled water for ten minutes. They were then taken out of the water, blotted dry and re-weighed. The results are shown in Table 2.1.

Table 2.1

chip	original mass / g	mass after ten minutes in distilled water / g
D	60	70
E	60	72

(a) Explain why the mass of both chips increased.

water potential of distilled water is higher than the water potential of cell sap of chips ;

Movement of water through a partially permeable membrane ; from region of high water potential to one of low water potential / down a water potential gradient ; via osmosis ; (must match the explanation given) [3]

(b) Explain why chip E gained more mass than chip D during the ten minutes.

chip E absorbed more water;
chip E had larger surface area to volume ratio;
larger area of membrane through which water could pass by osmosis ; more osmosis / movement of water molecules occurred ; in limited time ;

(ORA for chip D)
Max 2

[2]

(c) Fig. 2.2 shows a photograph of some red blood cells immersed in plasma as seen with a microscope.

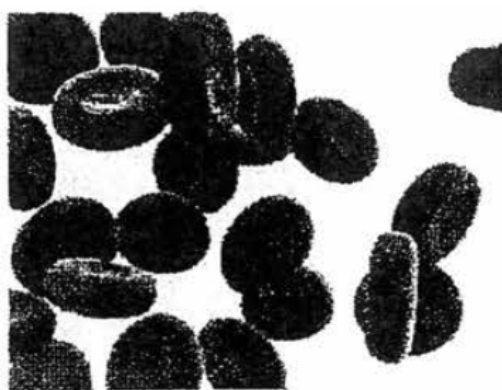

Fig. 2.2

Name the chemical that gives the cells their red colour.

[1]

haemoglobin ; (accept Hb/oxyhaemoglobin)

(d) A student extracted some of these cells and placed them on a slide in distilled water.
 After three minutes the student looked at the slide using a microscope.
 No cells were visible, but the surrounding liquid was coloured pink.

(i) Deduce what had occurred to the cells during the three-minute period;

water potential of distilled water is higher than the water potential of red blood cell (cytoplasm)

(ii) Explain how the human body is able to prevent such an occurrence..

osmosis occurred / water moved into / enters red blood cells ;
 cell bursts / cell membrane ruptures ;
 (because) no cell wall ;
 haemoglobin released into water (staining it pink) ;

[max 3] [1]

[2]

Total: [9]

12 Six strips of potato tissue, each 5.0 cm long, were obtained from a potato. Three strips were placed in water and another three were placed in 25% sugar solution.

After 1 hour, the cylinders were removed from the solutions, blotted dry and outlined onto graph paper as shown below.

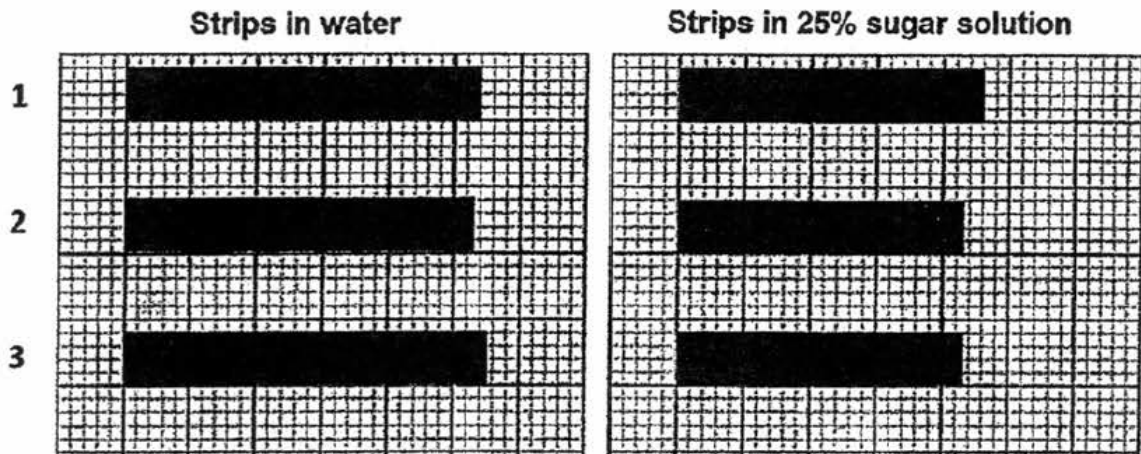

- (a) Record the new lengths of the strips (in 25% sugar solution) in the table below, then calculate the average length of the strips. [2]

Cylinder	Length of strip in water / cm	Length of strip in 25% sugar solution / cm
1	5.4	
2	5.3	
3	5.5	
Average length		

$$4.6 + 4.3 + 4.3 = 13.2 / 3 = 4.4$$

- (b) Explain why the strips change in length in
(i) water [2]

Water potential in water is higher than potato cell sap
Endosmosis occurred, causing potato cells to swell and so increased in length

- (ii) 25% sugar solution [2]

Water potential in potato cell sap is higher than 25% sugar solution
Exosmosis occurred, causing potato cells to shrink in size and so decreased in Length

- (c) Which other measurements could have been taken to show that the strips had changed during the experiment? [1]

Measure initial and final mass of strips

Total: 7m

- 13 Young vegetables like cucumber can be preserved for a long time by soaking them in brine (salt solution) as shown in Fig. 1.1. This soaking process removes moisture from the plant tissue and gives the cucumber a salty taste after the process.



Fig. 1.1

- (a) Explain how moisture is lost and a salty taste is acquired in the cucumber.

Moisture:

- Water molecules move out by osmosis as there is higher water potential in plant tissue than brine [1]

Salt

- Salt molecules diffuse into plant tissue as concentration of salt molecules in brine is higher than in cucumber tissues [1]

[2]

- (b) State the term that describes the condition of plant tissues in this state.

Flaccid /plasmolysis/ plasmolysed

[1]

(c) Fig. 1.2 shows how a cell of the cucumber looks like before the soaking process.

In the box below Fig 1.2, draw how the cell looks like after the soaking.

(Your answer should include labels for cell membrane, tonoplast)



Fig. 1.2: Cell *before* soaking in brine

Drawing of cell after soaking in brine

- Drawing of cell and vacuole size smaller than original (marker is tonoplast) [1]
- Cell membrane torn away from cell wall (at least draw once) [1]
- Correct label of tonoplast and cell membrane [1]