

Name:	Target Grade:	Actual Grade:
-------	---------------	---------------



## COVALENT BONDING MCQ and STRUCTURED QUESTIONS

**READ THESE INSTRUCTIONS FIRST**

### INSTRUCTIONS TO CANDIDATES

1. Find a quiet, comfortable spot free place from distractions.
2. Spend one minute on each mark.
3. Time yourself for every single question.
4. Every chapter has their own question types. Ensure that you know the different question type for each chapter.
5. Make a conscientious effort to remember your mistakes, especially in terms of answering techniques. E.g Take a picture for the mistakes that you made, keep it in a photo album, and revise it over and over again.
6. Highlight question types that you tend to keep making mistakes and review them nearing exams.
7. Always review the common questions and question type that you tend to make mistakes nearing exams.
8. During exams, classify the question type and recall what you have learnt, how you need to analyse the questions for the different question type, what you need to take note of and answer with the correct answering techniques!

✨ Wishing you all the best for this test!

You've got this!

💡 With lots of love,  
Bright Culture 🧡

If you are struggling in this paper, means you need to work harder!

If you need any professional guidance and further advice on how to advance, feel free to WhatsApp us at 91870820 or find us at [www.bright-culture.com/](http://www.bright-culture.com/). We are committed to connect you to your future to reach your goals.

**MARKS**

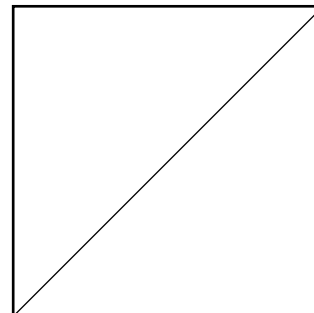

**COVALENT BONDING MCQ**

**Paper 1**

- 1 Which statements correctly describes the properties of mixtures of iron and sulfur, and the compound iron(II) sulfide, FeS?

	mixtures of iron and sulfur	compound iron(II) sulfide
1	iron and sulfur mix without chemically reacting	iron and sulfur combine in a chemical reaction to form iron(II) sulfide
2	the ratio of iron to sulfur in mixture can vary	the ratio of iron to sulfur in iron(II) sulfide is always the same
3	the mixtures do not have the properties of iron or sulfur	iron(II) sulfide has the properties of iron and sulfur

- A** 1 only  
**B** 1 and 2  
**C** 2 and 3  
**D** 3 only

- 2 The diagram shows the structural formula of propyl methanoate.

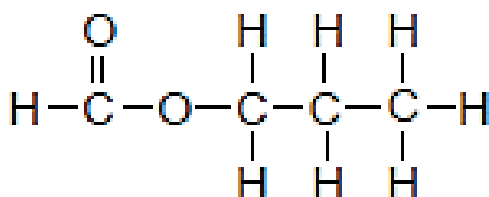

What is the total number of electrons that are **not** involved in chemical bonding in the molecule?

- A** 8  
**B** 14  
**C** 20  
**D** 28

- 3 The table shows four elements W, X, Y and Z with their atomic numbers.

element	W	X	Y	Z
atomic number	6	8	11	17

What are the likely formulae of ionic compound and covalent compound formed from the four elements?

	formula of ionic compound	formula of covalent compound
<b>A</b>	W X	YZ
<b>B</b>	Y <sub>2</sub> X	WX <sub>2</sub>
<b>C</b>	YW	WZ <sub>4</sub>
<b>D</b>	YZ	ZX

4 Peeling onions often causes tearing of the eyes due to the release of a sulfide compound. Peeling them under running water reduces the problem. Which of the following statements are true of the sulfide compound?

- I. It is soluble in water
- II. It has low boiling point.
- III. It has small and light ions with weak bonding.
- IV. It is a covalent compound with weak covalent bonds.

- A I and II only
- B I and IV only
- C I, II and III only
- D I, II and IV only

5 Element X forms the ion  $X^{2-}$  with the following structure:

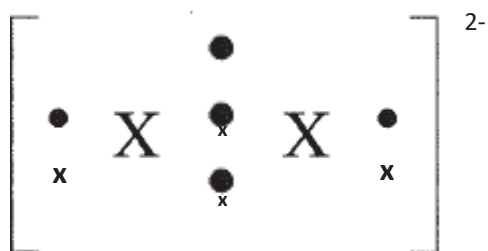

What is the formula of the covalent compound X forms with chlorine?

- A  $XCl$
- B  $XCl_2$
- C  $XCl_3$
- D  $XCl_4$

6 Slate has a layered structure and is slippery.

Which diagram shows a structure that closely resembles slate?

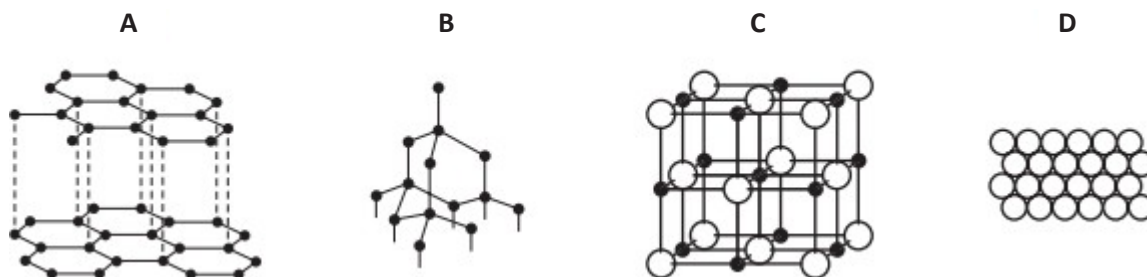

- 7 The electronic structure of a compound formed between an element Y and chlorine is shown in the diagram. Only valence electrons are shown.

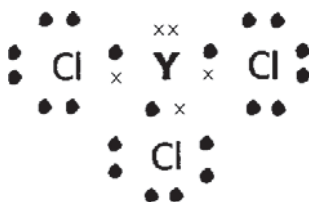

What is the chemical formula when sodium combines with element Y?

- A  $\text{Na}_2\text{Y}$
  - B  $\text{NaY}_2$
  - C  $\text{Na}_3\text{Y}$
  - D  $\text{Na}_5\text{Y}$
- 8 The following table shows four elements P, Q, R and S with their proton numbers.

elements	P	Q	R	S
proton number	6	8	17	19

Which are the likely formulae of the ionic compound and covalent compound formed from the four elements?

	ionic compound	covalent compound
A	$\text{PR}_4$	SR
B	$\text{S}_2\text{Q}$	$\text{PQ}_2$
C	SP	$\text{PR}_4$
D	SR	RQ

- 9 Graphane, an allotrope of carbon, has a structure similar to graphite. Graphane, however, has one hydrogen atom attached to each carbon as shown in the diagram.

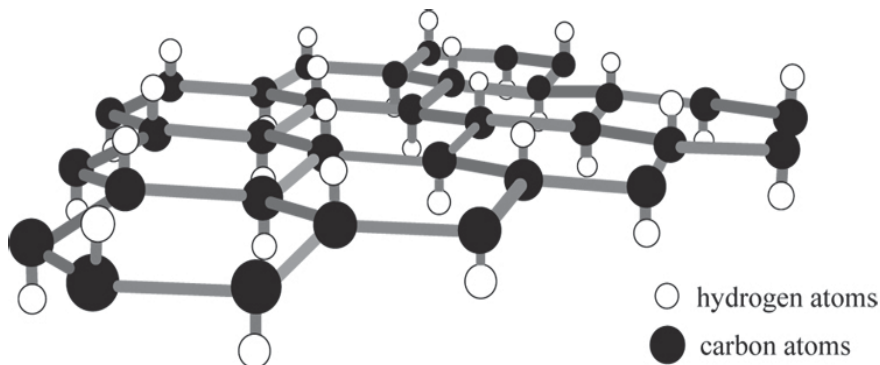

Which set of properties will graphane have?

- 1 It is soluble in water.
  - 2 It has a high melting point.
  - 3 It has a giant molecular structure.
  - 4 It conducts electricity in the solid state.
- A 1 and 2 only
  - B 2 and 3 only
  - C 1, 2 and 3 only
  - D 1, 2, 3 and 4

10 Trioxidane has the formula  $H_2O_3$ .

Which is the most likely structure of trioxidane?

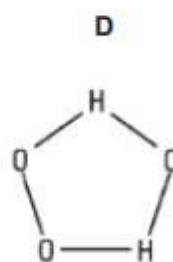
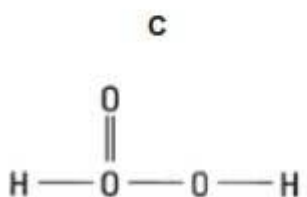
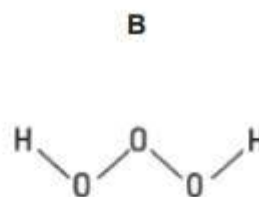
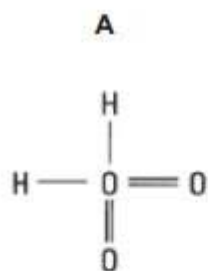

11 Which molecule has the largest number of electrons involved in covalent bonds?

- A  $C_2H_4$
- B  $CO_2$
- C  $CH_3OH$
- D  $N_2$

12 The electronic structure of two atoms P and Q are shown.

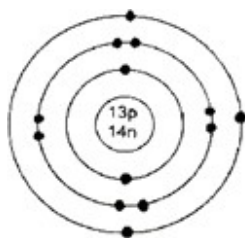

atom P

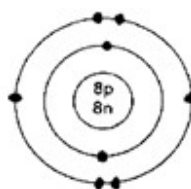

atom Q

What is the type of chemical bonding and the mass of one mole of compound formed between these two elements?

	type of bonding	mass of one mole of compound / g
A	covalent bonding	70
B	covalent bonding	113
C	ionic bonding	43
D	ionic bonding	102

- 13 Fires are categorized into four different classes according to the type of fuel involved. The table below shows the various classes of fire.

class	fuel/heat Source	example
1	ordinarily combustible	solids like wood and coal on fire
2	flammable liquids	petrol, oil on fire
3	flammable gases	natural gas, carbon monoxide on fire
4	combustible metals	sodium or potassium on fire

In a selection test, a potential firefighter is required to match four substances according to their class of fire.

Which of the following has been incorrectly matched? (Assume room temperature and pressure).

	melting point/ $^{\circ}\text{C}$	boiling point/ $^{\circ}\text{C}$	class of fire
<b>A</b>	98	883	4
<b>B</b>	-184	-164	3
<b>C</b>	-117	78	1
<b>D</b>	5	80	2

- 14 A sample of a white crystalline substance is heated in the absence of oxygen. It melts sharply at  $120^{\circ}\text{C}$ , but on further heating, gives off smoky fumes and a black solid remains.

From this information, we may deduce that the white crystalline substance is

- A** an element which combusted to form two products.
  - B** a mixture of substances which combined chemically.
  - C** a compound which combusted to form two products.
  - D** a compound which decomposed to form simpler substances.
- 15 The diagram below shows the bonding between P and Q in the covalent molecule,  $\text{PQ}_2$ .

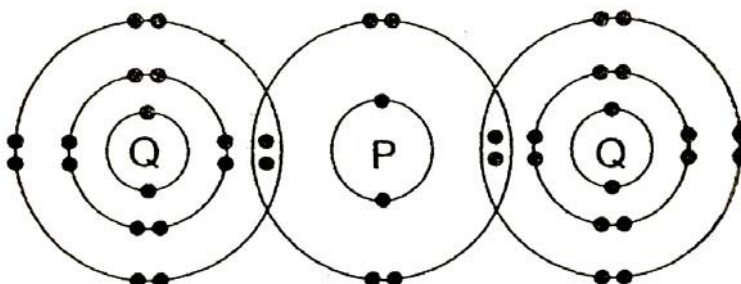

What are the electronic structures of atoms P and Q before combining together to form the above molecule?

	P	Q
<b>A</b>	2.6	2.8.6
<b>B</b>	2.4	2.8.7
<b>C</b>	2.6	2.8.7
<b>D</b>	2.8	2.8.8

- 16** Graphane has a similar structure to graphite, except that, it has an additional hydrogen atom attached to each carbon as shown in the diagram.

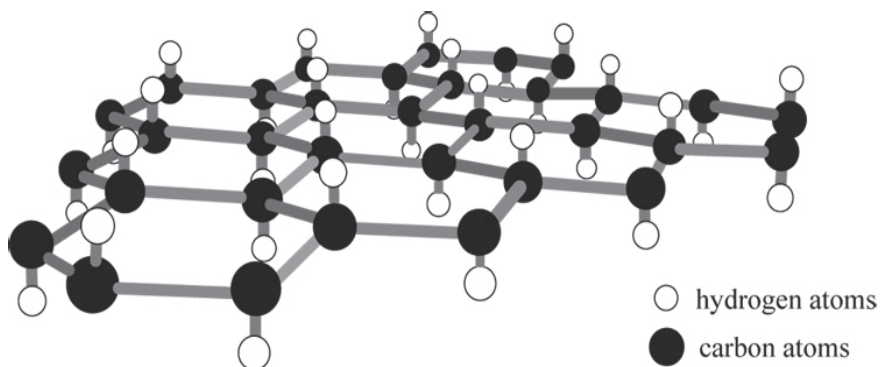

Which set of properties will graphane have?

1	It has a high melting and boiling point.
2	It has a giant molecular structure.
3	It conducts electricity in the solid state.

- A** 1 and 2  
**B** 1 and 3  
**C** 2 and 3  
**D** 1, 2 and 3
- 17** Elements **P** and **Q** are found in Groups V and VII of the Periodic Table respectively.

What is the chemical formula of a compound formed between **P** and **Q**?

- A** **PQ**  
**B** **PQ<sub>3</sub>**  
**C** **P<sub>2</sub>Q<sub>3</sub>**  
**D** **P<sub>3</sub>Q<sub>2</sub>**

- 18 The structural formula of phosgene,  $\text{COCl}_2$ , is shown.

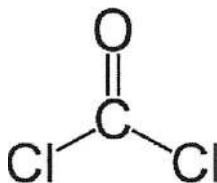

How many electrons in this molecule are **not** involved in formation of bonds?

- A 16
  - B 24
  - C 36
  - D 40
- 19 In the molecule shown below, how many electrons are **not** involved in bonding?

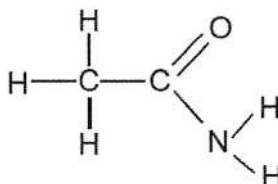

- A 6
  - B 8
  - C 12
  - D 14
- 20 A unit of buckminsterfullerene,  $\text{C}_{60}$ , contains sixty carbon atoms chemically combined together in a sphere, as shown below.

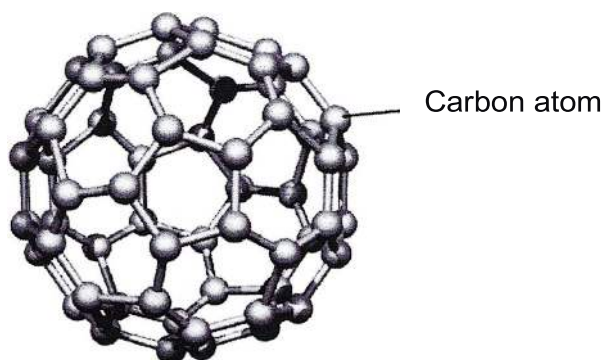



Which of the following statements best describes buckminsterfullerene?

- A Buckminsterfullerene exists as a covalent compound.
- B Buckminsterfullerene exists as an ionic compound.
- C Buckminsterfullerene has a simple molecular structure.
- D Buckminsterfullerene is made up of many hexagonal layers.

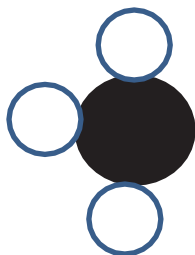
21 The following diagram shows the structure of one molecule of a substance.



What are the possible electronic configurations for the elements in the above substance?

		
<b>A</b>	1	2.3
<b>B</b>	2.6	2.5
<b>C</b>	2.7	2.3
<b>D</b>	2.8.7	2.5

22 A molecule consists of three types of elements, P, X and Y.

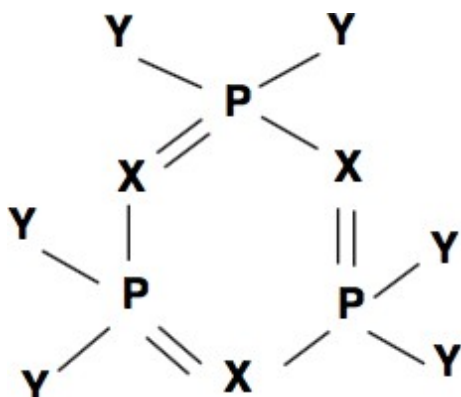

If P is phosphorus, what could X and Y be?

	X	Y
<b>A</b>	Al	H
<b>B</b>	N	Cl
<b>C</b>	O	H
<b>D</b>	Si	Cl

23 The shapes and names of some molecules are shown below.

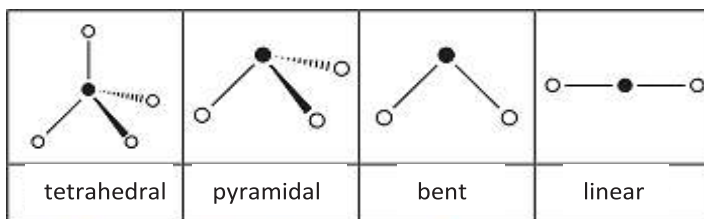

Phosphine is a compound of phosphorus, an element in Group V, and hydrogen. The shape of a molecule of phosphine is likely to be

- A bent.
- B linear.
- C pyramidal.
- D tetrahedral.

24 A molecule of sulfuric acid has the structural formula shown.

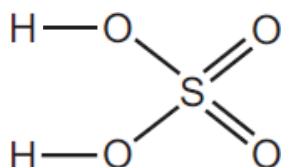

How many electrons are involved in forming all the covalent bonds in one molecule of sulfuric acid?

- A 6
- B 8
- C 12
- D 16

25 The diagram shows the structure of hexagonal boron nitride.

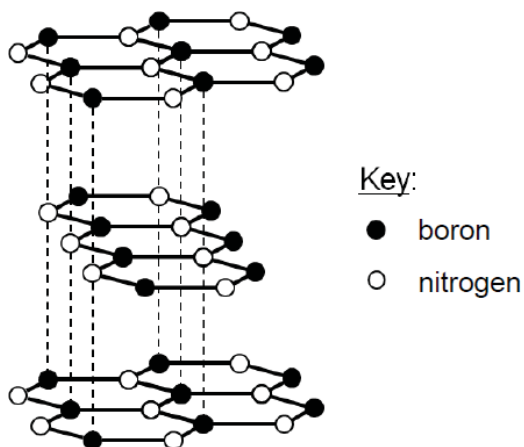

Which property is hexagonal boron nitride most likely to have?

- A It is soluble in water.
- B It has a low melting point.
- C It is soft and acts as a lubricant.
- D It does not conduct electricity in solid state but conducts electricity in liquid state.

26 Which statement is **not** true for all metals when they are in solid state?

- A They conduct heat.
- B They are malleable.
- C They conduct electricity.
- D They form coloured compounds.

27 All of the following substances can conduct electricity.

Which substance's conductivity is not due to the movement of electrons?

- A aluminium
- B graphite
- C lithium chloride
- D mercury

28 Which statement about diamond and graphite is correct?

- A Both diamond and graphite are used as abrasives.
- B Diamond and graphite have different arrangements of carbon atoms.
- C The carbon atoms in graphite have a different number of neutrons from those in diamond.
- D The carbon atoms in both graphite and diamond have four covalent bonds.

29 A colourless crystalline solid melts below 150°C and dissolves in water to give a solution that does not conduct electricity. What could the solid be?

- A copper, Cu
- B glucose, C<sub>6</sub>H<sub>12</sub>O<sub>6</sub>
- C silicon dioxide, SiO<sub>2</sub>
- D sodium chloride, NaCl

30 Element X is an element in Group III of the Periodic Table. What is the formula of a chloride of X?

- A X<sub>3</sub>Cl
- B X<sub>2</sub>Cl<sub>3</sub>
- C X<sub>3</sub>Cl<sub>3</sub>
- D XCl<sub>3</sub>

31 **X**, **Y** and **Z** are three elements with consecutive proton numbers. **X** has the lowest proton number and **Y** is a noble gas.

How is a stable compound formed between **X** and **Z**?

- A** Each atom of **X** shares a pair of electrons with an atom of **Z**.
- B** Each atom of **X** receives an electron from an atom of **Z** to form  $\text{X}^+\text{Z}^-$ .
- C** Each atom of **X** gives an electron to an atom of **Z** to form  $\text{X}^-\text{Z}^+$ .
- D** Each atom of **X** receives an electron from an atom of **Z** to form  $\text{X}^-\text{Z}^+$ .

32 In which of the following is there no covalent bond?

- A** aluminium fluoride
- B** diamond
- C** sodium sulfate
- D** sulfur dioxide

33 Which solid does **not** contain covalent bonds?

- A** copper
- B** diamond
- C** graphite
- D** ice

34 The elements **X** and **Y** form the compound  $\text{X}_2\text{Y}$ . What is the correct electronic arrangement of the atoms of **X** and **Y**?

	electronic arrangement	
	atom of <b>X</b>	atom of <b>Y</b>
<b>A</b>	2,7	2
<b>B</b>	2,2	2,7
<b>C</b>	2,2	2,6
<b>D</b>	2,1	2,6

**COVALENT BONDING STRUCTURED QUESTIONS**

**Paper 2 Section A**

- 1 This question concerns the chemistry of carbon and silicon, elements from Group IV of the Periodic Table.

**Table 2.1** provides some information on two different forms of carbon (allotropes) and silicon:

<b>Substance</b>	<b>Melting point / °C</b>	<b>Electrical conductivity</b>	<b>Uses</b>
Carbon allotrope <b>A</b>	Above 3000	Poor	Cutting tools, drill bits
Carbon allotrope <b>B</b>	Above 3000	Good	Lubricant
Silicon	1414	Good	Semiconductors in electronics

- (a) Carbon tends to form covalent compounds.

By drawing the dot-and-cross diagram of a carbon compound of your choice, describe how a covalent bond is formed. You only need to show valence electrons.

.....  
 .....  
 .....  
 .....[3]

- (b) Explain, in terms of structure and bonding, why carbon allotrope **A** can be used as a drill bit while carbon allotrope **B** can be used as a lubricant.

.....  
 .....  
 .....  
 .....[2]

- (c) Carbon is commonly used as a reducing agent. For example, it can reduce zinc oxide to form zinc.

Explain, using oxidation states, how carbon is acting as a reducing agent in the reduction of zinc oxide.

.....  
 .....  
 .....[1]

**[Total: 6 marks]**

**Paper 2 Section B**

- 1 Silicon dioxide, also known as silica, is a chemical compound that is an oxide of silicon. Silica, in the form of sand is used as the main ingredient in sand casting for the manufacture of various metallic components in engineering.

A diagram of a silicon dioxide is shown below.

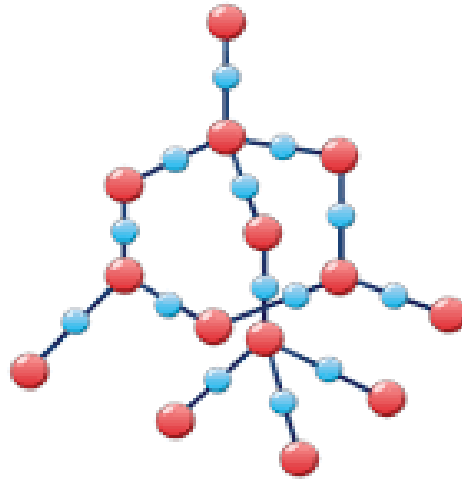

- (a) State one similarity and one difference between the structure of silicon dioxide and structure of diamond.

.....  
.....  
.....  
.....

[2]

- (b) Both diamond and silicon dioxide are poor electrical conductors.

State the name of another form of carbon which can conduct electricity.

How is this form of carbon different in structure from silicon dioxide which allows it to conduct electricity?

.....  
.....  
.....  
.....

[2]

- (c) Soda-lime glass is made by heating a mixture of calcium carbonate, sodium carbonate and sand in a furnace to a high temperature.

Other glasses contain compounds called silicates. The structures of soda-lime glass and silicate are shown in **Fig. 9**

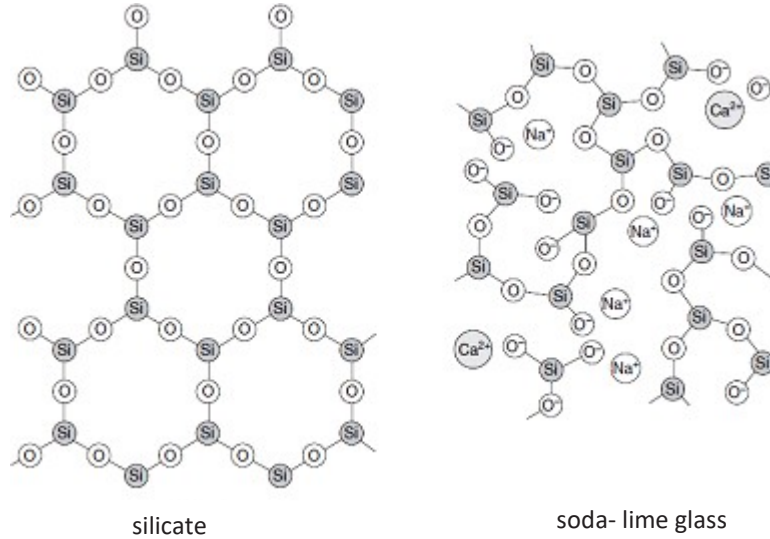

**Fig.9**

- (i) State one structural difference between soda-lime glass and silicate.

.....  
 ..... [1]

- (ii) Is soda-lime able to conduct electricity? Explain your answer.

.....  
 .....  
 .....  
 .....  
 ..... [3]

[Total: 8 marks]

2 Read the information below about the chlorides of elements in Period 3 of the Periodic Table.

### Elements and their chlorides

The formulae and chemical properties of the chlorides of the elements change across Period 3.

The chlorides behave differently when they are added to water. Some the chlorides dissolve in water to form a solution. Some hydrolyse when they are added to water. This means that they react chemically with water to produce new products.

element	metal / non-metal	formula of main chloride	bonding in chloride	effect of adding chloride to water	products of adding chloride to water
Na	metal	$\text{NaCl}$	ionic	dissolves	$\text{NaCl(aq)}$
Mg	metal	$\text{MgCl}_2$	ionic	dissolves	$\text{MgCl}_2\text{(aq)}$
Al	metal	$\text{AlCl}_3$	covalent	hydrolyses	Complex mixture of products including $\text{HCl(aq)}$
Si	non-metal	$\text{SiCl}_4$	covalent	hydrolyses	$\text{SiO}_2\text{(s)}$ $\text{HCl(aq)}$
P	non-metal	$\text{PCl}_3$	covalent	hydrolyses	$\text{H}_3\text{PO}_3\text{(aq)}$ $\text{HCl(aq)}$
S	non-metal	$\text{S}_2\text{Cl}_2$	covalent	hydrolyses	complex mixture of products including $\text{HCl(aq)}$
Cl	non-metal	$\text{Cl}_2$	covalent	hydrolyses	$\text{HClO(aq)}$ $\text{HCl(aq)}$

The chlorides have a different formulae and the ratio of the element to chlorine changes across Period 3. Some examples are shown in the table below.

formula of chloride	ratio of element to chlorine
$\text{NaCl}$	1:1
$\text{MgCl}_2$	1:2
$\text{AlCl}_3$	1:3

(a) Describe the pattern for the ratio of each element to chlorine across period 3. Include ratios in your answer.

.....

.....

..... [2]

(b) (i) Which chloride forms a precipitate when it is added to water?

..... [1]

(ii) Write a balanced equation for the reaction of phosphorus (III) chloride with water.

..... [1]

(c) Two students talk about the data.

Student 1: 'I think that whether or not the chloride hydrolyses is linked to the metal or non-metal character of the element.'

Student 2: 'I think that whether or not the chloride hydrolyses is linked to the bonding of the chloride.'

Does the information in the table support the ideas of the students? Explain your reasoning.

.....

.....

.....

.....

..... [3]

(d) Another student performs an experiment to test whether some other chlorides dissolve or hydrolyse when they are added to water.

He adds each chloride to water and tests the pH of the mixture.

Explain how the result of a pH test shows whether or not a chloride has hydrolysed.

.....

.....

.....

..... [2]

- (e) Suggest a reason why argon is not included in the table of information about Period 3 chlorides.

.....  
 ..... [1]

[Total: 10 marks]

- 3 The structure of a molecule of an oxide of phosphorous is shown in Fig.

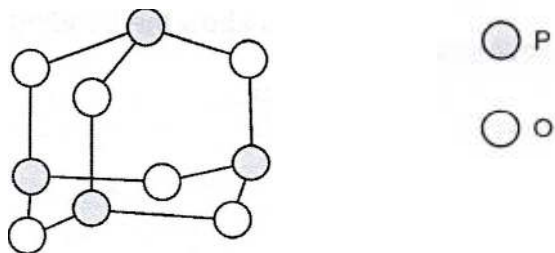

Fig. 3

- (a) Explain fully each of the following properties of this oxide of phosphorous, with reference to its bonding and structure where necessary .

**Property 1:** This oxide has a low melting point

*Explanation*.....  
 .....  
 ..... [2]

**Property 2:** This oxide is acidic.

*Explanation* .....  
 ..... [1]

- (b) State one other likely property of this oxide of phosphorous.

.....  
 ..... [1]

[Total: 4 marks]

- 4 (a) In the figure below, ethylamine gas,  $C_2H_5NH_2$ , reacts with hydrogen chloride gas,  $HCl$ , to form solid ethylammonium chloride, which appears as a white ring. **A**, **B** and **C** are three possible positions where the white ring can appear.

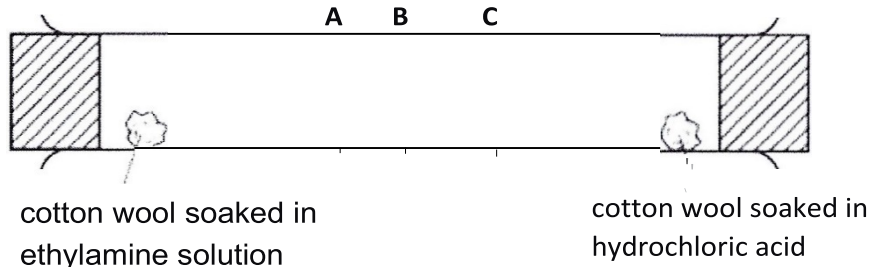

- (i) Given that **B** is the mid-point of the tube, predict the position, **A**, **B** or **C**, at which the white ring of ethylammonium chloride will form. Explain your answer.

.....

.....

.....

.....

.....

.....

.....

[3]

- (ii) The reaction is repeated at a higher temperature. Predict if the position and rate at which the white ring is formed changes. Explain your answer.

.....

.....

.....

.....

.....

[2]



5 Carbon atoms can bond to each other to produce a variety of different structures, including diamond, graphite and buckminsterfullerene.

(a) There are similarities and differences in the structure and bonding in diamond and graphite.

(i) Describe two features of the structure and bonding in diamond that are similar to graphite.

.....  
.....  
.....  
..... [2]

(ii) Describe two features of the structure and bonding in diamond that are different from graphite.

.....  
.....  
.....  
..... [2]

(b) Buckminsterfullerene is a form carbon with the formula  $C_{60}$ . If it is burned completely in oxygen, it forms carbon dioxide as the only product. Calculate the mass of carbon dioxide that is released when 51 g of buckminsterfullerene is completely burned in oxygen. [2]

(c) The structures of graphite and boron nitride are shown below.

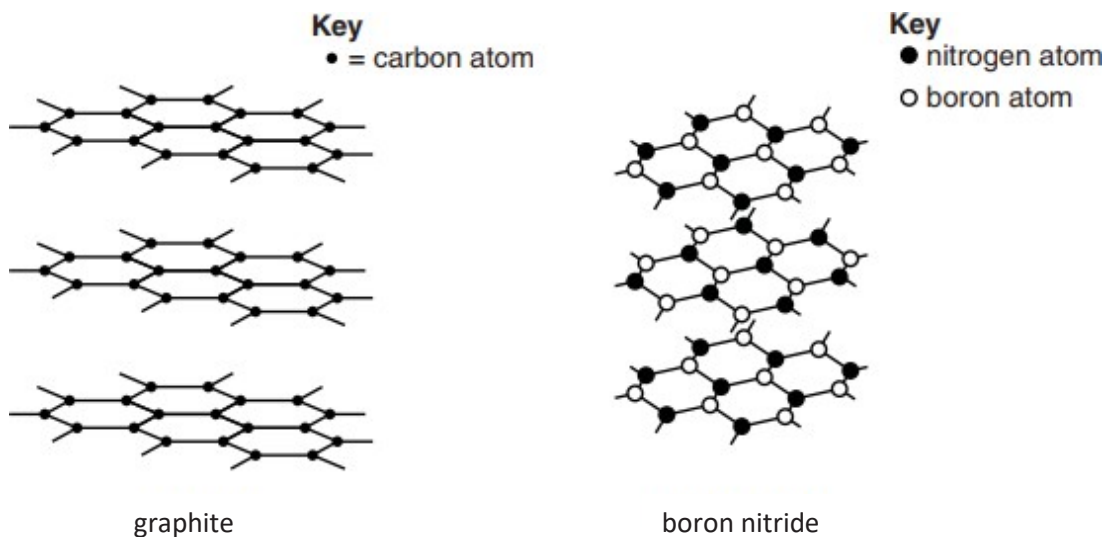

(i) What is the chemical formula for boron nitride? ..... [1]

(ii) Like graphite, boron nitride feels slippery to the touch.  
Explain, in terms of bonding and structure, why boron nitride feels slippery to touch.

.....

.....

.....

..... [2]

(iii) The diagram below shows the structure of a solid form of carbon called graphene. Graphene contains **one layer** of carbon atoms. Graphene is made from graphite but it is harder than graphite.

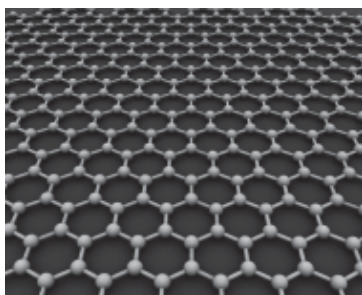

Explain, using ideas about structure and bonding, why graphene is hard.

.....

..... [1]

6 The following table shows some substances and their properties.

substance	melting point (°C)	boiling point (°C)	solubility in water	electrical conductivity	
				when solid	when liquid
<b>A</b>	3550	4830	insoluble	poor	poor
<b>B</b>	-55.6	-78.5	slightly soluble	poor	poor
<b>C</b>	1085	2562	insoluble	good	good
<b>D</b>	801	1413	soluble	poor	good
<b>E</b>	-38.8	357	insoluble	good	good

(a) Using the letters **A**, **B**, **C**, **D** and **E**, which substance(s) is/are likely to have a

(i) simple molecular structure, ..... [1]

(ii) giant covalent structure, ..... [1]

(iii) giant metallic structure. .... [1]

(b) Suggest a possible identity for element **E**. [1]

.....

(c) A student passed a current through molten substance **D** and after a while, a gas which rekindled a glowing splint was produced at the anode.

Write an ionic half-equation, including state symbols, for the reaction that happened at the anode.

..... [2]

[Total: 6]

7 (a) Silicon has three naturally occurring isotopes.

Complete Table 3.1 for two of these isotopes.

Table 3.1

isotope	$^{28}\text{Si}$	$^{30}\text{Si}$
atomic number		14
number of neutrons	14	
nucleon number		

[2]

(b) Silicon(IV) chloride is a simple molecular compound and exists as a liquid at room temperature.

a. Suggest **two** physical properties of silicon(IV) chloride, other than solubility.

.....

.....[2]

b. Draw a diagram to show the arrangement of electrons in a molecule of silicon(IV) chloride. You only need to show outer shell electrons.

[2]

(c) Silicon(IV) chloride reacts with water to form silicon(IV) oxide and an acidic product.

Fig. 3.2 shows part of the structure of silicon(IV) oxide.

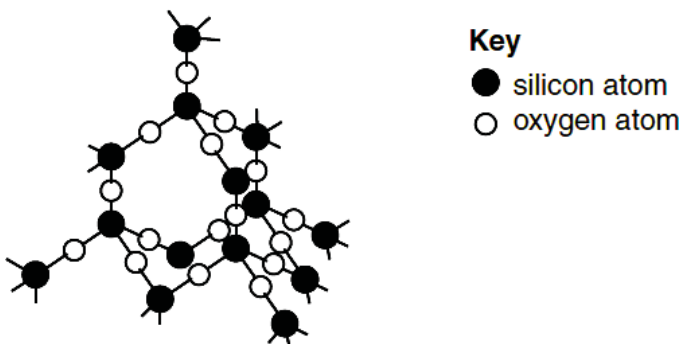

Fig. 3.2

(i) Construct an equation, including state symbols, for the reaction between silicon(IV) chloride with water.

.....[2]

(ii) A student claims that the physical properties of silicon(IV) oxide is similar to that of silicon(IV) chloride.

Explain, in terms of structure and bonding, why the student's claim is wrong.

.....

.....

.....

.....[2]

[Total: 10]

8 Each of the letter's **P, Q, R, S** and **W** represents a particular substance.

Answer the questions by referring to the data given in the table below.

Substance	Melting Point (°C)	Boiling Point (°C)	Electrical Conductivity		Reaction with water	Effect of heat
			solid state	liquid state		
<b>P</b>	800	1413	Non-conductor	Good conductor	Soluble in water to form a neutral solution	Melts on heating but no new substance is formed.
<b>Q</b>	63	967	Good conductor	Good conductor	Reacts with cold water, producing hydrogen and an alkali	Burns easily, forming an oxide which dissolves in water to form an alkali
<b>R</b>	-110	45	Non-conductor	Non-conductor	Insoluble in water	Burns easily, producing carbon dioxide and water
<b>S</b>	1677	2230	Non-conductor	Non-conductor	Insoluble in water	Melts without forming any new substance
<b>W</b>	2580	2850	Non-conductor	Good conductor	Soluble in water to form an alkali	Melts without forming any new substance

- (a) Which substance exists as simple molecules? \_\_\_\_\_ [1]
- (b) Which substance is a metal? \_\_\_\_\_ [1]
- (c) Which substance has a macromolecular structure? \_\_\_\_\_ [1]
- (d) List the ionic compounds \_\_\_\_\_ [1]
- (e) Name the particles present in **Q** that allows it to conduct electricity. [1]

- (f) Name the two elements that must be found in substance **R**. [1]

- 9 **P, Q, R, X, Y** and **Z** are consecutive elements of the Periodic Table. The table below shows the formulae of the oxide compounds of these elements.

element	formula of oxide
<b>P</b>	<b>PO<sub>2</sub></b> and <b>PO</b>
<b>Q</b>	<b>Q<sub>2</sub>O<sub>5</sub></b>
<b>R</b>	<b>RO<sub>3</sub></b>
<b>X</b>	<b>X<sub>2</sub>O<sub>7</sub></b>
<b>Y</b>	does not form any oxide
<b>Z</b>	<b>Z<sub>2</sub>O</b>

- (a) In which Group of the Periodic Table would you expect to find
- (i) element **P** : \_\_\_\_\_ [1]
- (ii) element **Y** : \_\_\_\_\_ [1]
- (iii) element **Z** : \_\_\_\_\_ [1]
- (b) What is the formula of the compound formed between the elements **P** and **X**? [1]
- \_\_\_\_\_
- (c) Which of the oxide in the table above is an ionic compound? Give a reason for your answer. [2]
- \_\_\_\_\_
- \_\_\_\_\_
- (d) Write a balanced chemical equation to show the reaction of element **Z** in air to form **Z<sub>2</sub>O**. [1]
- \_\_\_\_\_

- 10 The table below shows the atomic number and mass number of element **X** and **Y** (which are not the real symbols of the elements).

element	atomic number	mass number
<b>X</b>	7	14
<b>Y</b>	17	35

- (a) Write the electronic configuration of **X**. [1]

- (b) To which group of the Periodic Table does **Y** belong? Give a reason for your answer. [2]

- (c) Draw a 'dot-and-cross' diagram to represent the electronic structure of the compound formed between **X** and **Y**. [2]

- 11 The table below shows the atomic number and mass number of elements **X** and **Y** (which are not the symbols of the elements).

element	atomic number	mass number
<b>X</b>	12	24
<b>Y</b>	17	35

Using the information given, answer the following questions.

- (a) Write the electronic configuration of **Y**. [1]

- (b) Write down the formula for the oxide of **X**. [1]

(c) (i) What is the type of bonding that is present in the compound formed by **X** and **Y**? Give an explanation for your answer.

[2]

---

---

(ii) By showing **all** the electrons, draw a 'dot-and-cross' diagram to show the bonding in the compound formed by **X** and **Y**.

**ANSWERS FOR COVALENT BONDING MCQ**

**Paper 1**

- 1 Which statements correctly describes the properties of mixtures of iron and sulfur, and the compound iron(II) sulfide, FeS?

	mixtures of iron and sulfur	compound iron(II) sulfide
1	iron and sulfur mix without chemically reacting	iron and sulfur combine in a chemical reaction to form iron(II) sulfide
2	the ratio of iron to sulfur in mixture can vary	the ratio of iron to sulfur in iron(II) sulfide is always the same
3	the mixtures do not have the properties of iron or sulfur	iron(II) sulfide has the properties of iron and sulfur

- A 1 only  
**B 1 and 2**  
 C 2 and 3  
 D 3 only

- 2 The diagram shows the structural formula of propyl methanoate.

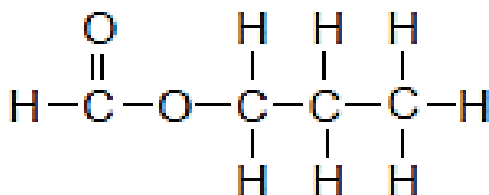

What is the total number of electrons that are **not** involved in chemical bonding in the molecule?

- A 8  
 B 14  
**C 20**  
 D 28

- 3 The table shows four elements W, X, Y and Z with their atomic numbers.

element	W	X	Y	Z
atomic number	6	8	11	17

What are the likely formulae of ionic compound and covalent compound formed from the four elements?

	formula of ionic compound	formula of covalent compound
A	W X	YZ
<b>B</b>	<b>Y<sub>2</sub>X</b>	<b>WX<sub>2</sub></b>
C	YW	WZ <sub>4</sub>
D	YZ	ZX

4 Peeling onions often causes tearing of the eyes due to the release of a sulfide compound. Peeling them under running water reduces the problem. Which of the following statements are true of the sulfide compound?

- I It is soluble in water
- II It has low boiling point.
- III It has small and light ions with weak bonding.
- IV It is a covalent compound with weak covalent bonds.

- A I and II only**
- B I and IV only
- C I, II and III only
- D I, II and IV only

5 Element X forms the ion  $X^{2-}$  with the following structure:

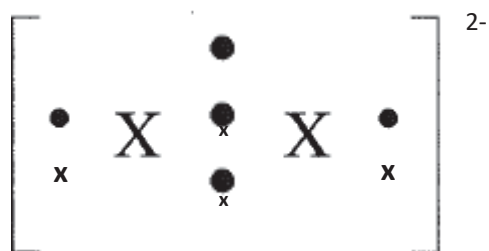

What is the formula of the covalent compound X forms with chlorine?

- A  $XCl$
- B  $XCl_2$
- C  $XCl_3$
- D  $XCl_4$**

6 Slate has a layered structure and is slippery.

Which diagram shows a structure that closely resembles slate? **Answers : D**

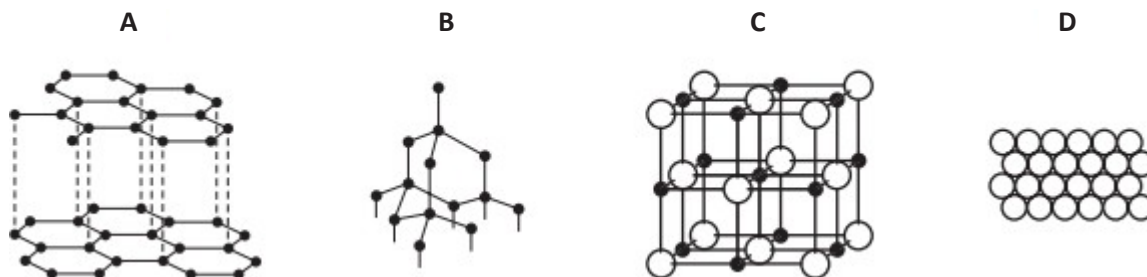

- 7 The electronic structure of a compound formed between an element Y and chlorine is shown in the diagram. Only valence electrons are shown.

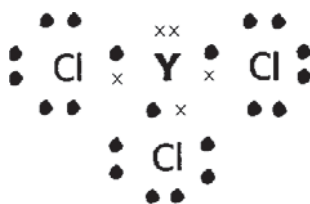

What is the chemical formula when sodium combines with element Y?

- A  $\text{Na}_2\text{Y}$
- B  $\text{NaY}_2$
- C  $\text{Na}_3\text{Y}$**
- D  $\text{Na}_5\text{Y}$

- 8 The following table shows four elements P, Q, R and S with their proton numbers.

elements	P	Q	R	S
proton number	6	8	17	19

Which are the likely formulae of the ionic compound and covalent compound formed from the four elements?

	ionic compound	covalent compound
<b>A</b>	$\text{PR}_4$	$\text{SR}$
<b>B</b>	$\text{S}_2\text{Q}$	$\text{PQ}_2$
<b>C</b>	$\text{SP}$	$\text{PR}_4$
<b>D</b>	$\text{SR}$	$\text{RQ}$

- 9 Graphane, an allotrope of carbon, has a structure similar to graphite. Graphane, however, has one hydrogen atom attached to each carbon as shown in the diagram.

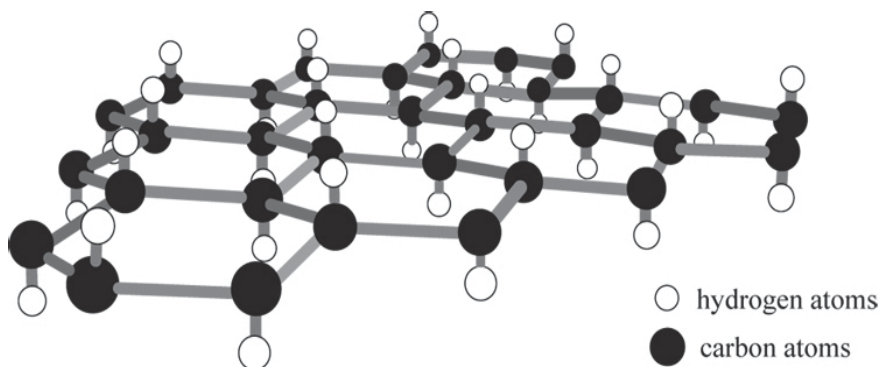

Which set of properties will graphane have?

- 1 It is soluble in water.
- 2 It has a high melting point.
- 3 It has a giant molecular structure.
- 4 It conducts electricity in the solid state.

- A 1 and 2 only
- B 2 and 3 only**
- C 1, 2 and 3 only
- D 1, 2, 3 and 4

10 Trioxidane has the formula  $H_2O_3$ .

Which is the most likely structure of trioxidane? **Answer: B**

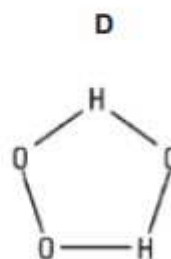
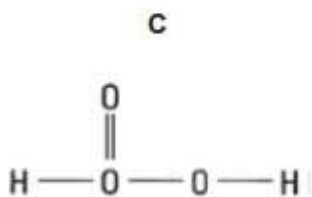
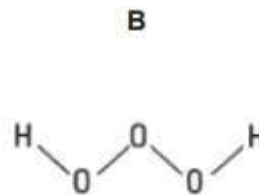
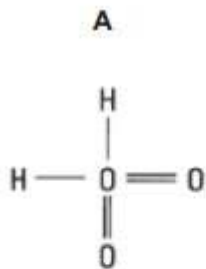

11 Which molecule has the largest number of electrons involved in covalent bonds?

- A**  $C_2H_4$
- B**  $CO_2$
- C**  $CH_3OH$
- D**  $N_2$

12 The electronic structure of two atoms P and Q are shown.

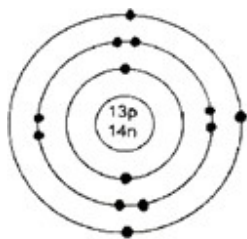

atom P

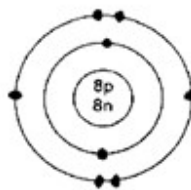

atom Q

What is the type of chemical bonding and the mass of one mole of compound formed between these two elements?

	type of bonding	mass of one mole of compound / g
<b>A</b>	covalent bonding	70
<b>B</b>	covalent bonding	113
<b>C</b>	ionic bonding	43
<b>D</b>	<b>ionic bonding</b>	<b>102</b>

- 13 Fires are categorized into four different classes according to the type of fuel involved. The table below shows the various classes of fire.

class	fuel/heat Source	example
1	ordinarily combustible	solids like wood and coal on fire
2	flammable liquids	petrol, oil on fire
3	flammable gases	natural gas, carbon monoxide on fire
4	combustible metals	sodium or potassium on fire

In a selection test, a potential firefighter is required to match four substances according to their class of fire.

Which of the following has been incorrectly matched? (Assume room temperature and pressure).

	melting point/°C	boiling point/°C	class of fire
<b>A</b>	98	883	4
<b>B</b>	-184	-164	3
<b>C</b>	-117	78	1
<b>D</b>	5	80	2

- 14 A sample of a white crystalline substance is heated in the absence of oxygen. It melts sharply at 120°C, but on further heating, gives off smoky fumes and a black solid remains.

From this information, we may deduce that the white crystalline substance is

- A an element which combusted to form two products.
- B a mixture of substances which combined chemically.
- C a compound which combusted to form two products.
- D a compound which decomposed to form simpler substances.**

- 15 The diagram below shows the bonding between P and Q in the covalent molecule, PQ<sub>2</sub>.

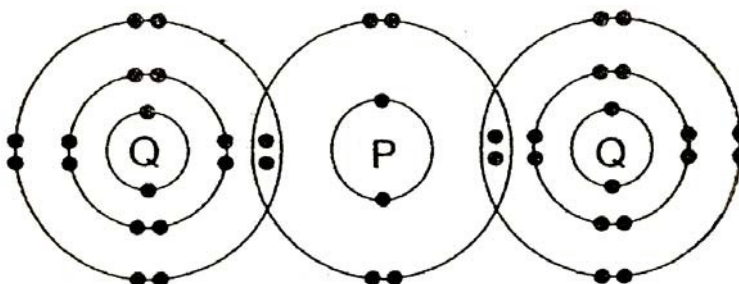

What are the electronic structures of atoms P and Q before combining together to form the above molecule?

	P	Q
A	2.6	2.8.6
B	2.4	2.8.7
C	2.6	2.8.7
D	2.8	2.8.8

- 16 Graphane has a similar structure to graphite, except that, it has an additional hydrogen atom attached to each carbon as shown in the diagram.

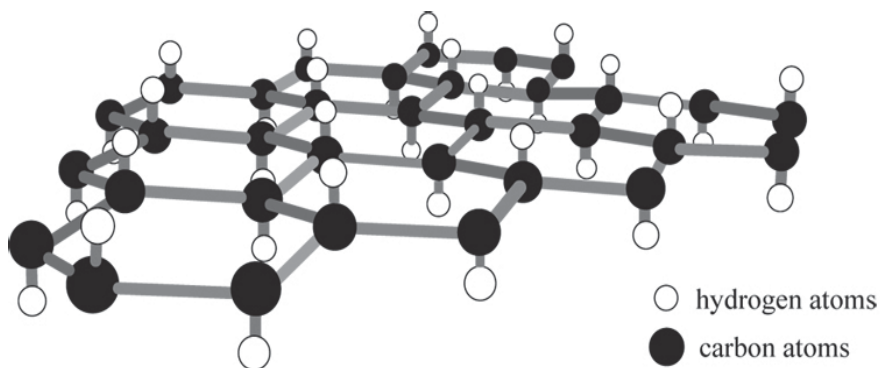

Which set of properties will graphane have?

1	It has a high melting and boiling point.
2	It has a giant molecular structure.
3	It conducts electricity in the solid state.

- A 1 and 2  
 B 1 and 3  
 C 2 and 3  
 D 1, 2 and 3
- 17 Elements P and Q are found in Groups V and VII of the Periodic Table respectively.

What is the chemical formula of a compound formed between P and Q?

- A PQ  
 B  $PQ_3$   
 C  $P_2Q_3$   
 D  $P_3Q_2$

18 The structural formula of phosgene,  $\text{COCl}_2$ , is shown.

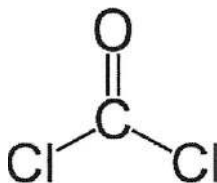

How many electrons in this molecule are **not** involved in formation of bonds?

- A 16
- B 24
- C 36
- D 40**

19 In the molecule shown below, how many electrons are **not** involved in bonding?

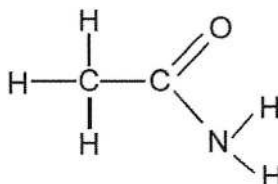

- A 6
- B 8
- C 12
- D 14**

20 A unit of buckminsterfullerene,  $\text{C}_{60}$ , contains sixty carbon atoms chemically combined together in a sphere, as shown below.

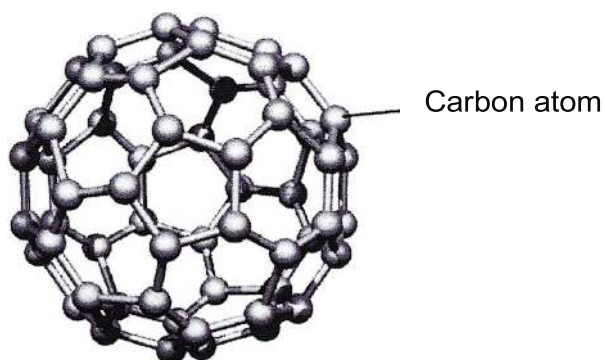



Which of the following statements best describes buckminsterfullerene?

- A Buckminsterfullerene exists as a covalent compound.
- B Buckminsterfullerene exists as an ionic compound.
- C Buckminsterfullerene has a simple molecular structure.**
- D Buckminsterfullerene is made up of many hexagonal layers.

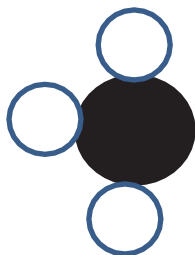
21 The following diagram shows the structure of one molecule of a substance.



What are the possible electronic configurations for the elements in the above substance?

		
<b>A</b>	1	2.3
<b>B</b>	2.6	2.5
<b>C</b>	2.7	2.3
<b>D</b>	2.8.7	2.5

22 A molecule consists of three types of elements, P, X and Y.

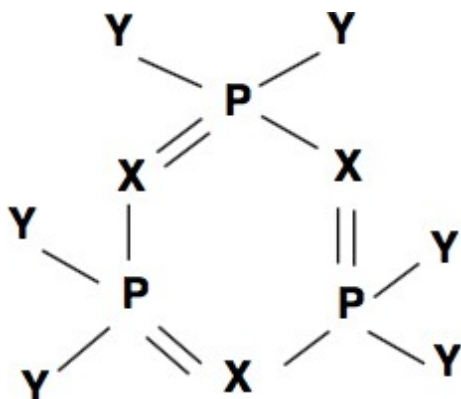

If P is phosphorus, what could X and Y be?

	X	Y
<b>A</b>	Al	H
<b>B</b>	N	Cl
<b>C</b>	O	H
<b>D</b>	Si	Cl

23 The shapes and names of some molecules are shown below.

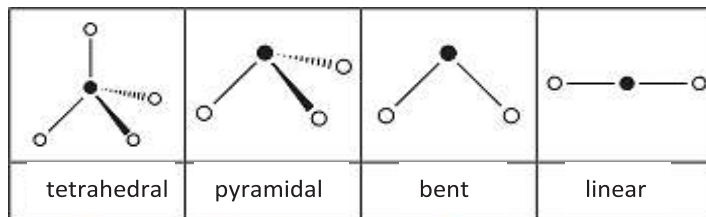

Phosphine is a compound of phosphorus, an element in Group V, and hydrogen. The shape of a molecule of phosphine is likely to be

- A bent.
- B linear.
- C pyramidal.**
- D tetrahedral.

24 A molecule of sulfuric acid has the structural formula shown.

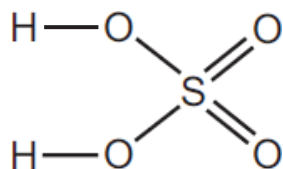

How many electrons are involved in forming all the covalent bonds in one molecule of sulfuric acid?

- A 6
- B 8
- C 12
- D 16**

25 The diagram shows the structure of hexagonal boron nitride.

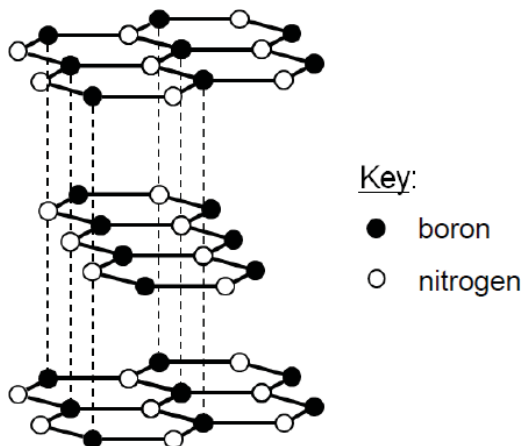

Which property is hexagonal boron nitride most likely to have?

- A It is soluble in water.
- B It has a low melting point.
- C It is soft and acts as a lubricant.**
- D It does not conduct electricity in solid state but conducts electricity in liquid state.

26 Which statement is **not** true for all metals when they are in solid state?

- A They conduct heat.
- B They are malleable.
- C They conduct electricity.
- D They form coloured compounds.**

27 All of the following substances can conduct electricity.  
Which substance's conductivity is not due to the movement of electrons?

- A aluminium
- B graphite
- C lithium chloride**
- D mercury

28 Which statement about diamond and graphite is correct?

- A Both diamond and graphite are used as abrasives.
- B Diamond and graphite have different arrangements of carbon atoms.**
- C The carbon atoms in graphite have a different number of neutrons from those in diamond.
- D The carbon atoms in both graphite and diamond have four covalent bonds.

29 A colourless crystalline solid melts below 150°C and dissolves in water to give a solution that does not conduct electricity. What could the solid be?

- A copper, Cu
- B glucose, C<sub>6</sub>H<sub>12</sub>O<sub>6</sub>**
- C silicon dioxide, SiO<sub>2</sub>
- D sodium chloride, NaCl

30 Element **X** is an element in Group III of the Periodic Table. What is the formula of a chloride of **X**?

- A X<sub>3</sub>Cl
- B X<sub>2</sub>Cl<sub>3</sub>
- C X<sub>3</sub>Cl<sub>3</sub>
- D XCl<sub>3</sub>**

- 31 **X**, **Y** and **Z** are three elements with consecutive proton numbers. **X** has the lowest proton number and **Y** is a noble gas.

How is a stable compound formed between **X** and **Z**?

- A** Each atom of **X** shares a pair of electrons with an atom of **Z**.  
**B** Each atom of **X** receives an electron from an atom of **Z** to form  $X^+Z^-$ .  
**C** Each atom of **X** gives an electron to an atom of **Z** to form  $XZ^+$ .  
**D** Each atom of **X** receives an electron from an atom of **Z** to form  $XZ^+$ .
- 32 In which of the following is there no covalent bond?
- A** aluminium fluoride  
**B** diamond  
**C** sodium sulfate  
**D** sulfur dioxide
- 33 Which solid does **not** contain covalent bonds?
- A** copper  
**B** diamond  
**C** graphite  
**D** ice
- 34 The elements **X** and **Y** form the compound  $X_2Y$ . What is the correct electronic arrangement of the atoms of **X** and **Y**?

	electronic arrangement	
	atom of <b>X</b>	atom of <b>Y</b>
<b>A</b>	2,7	2
<b>B</b>	2,2	2,7
<b>C</b>	2,2	2,6
<b>D</b>	2,1	2,6

**ANSWERS FOR COVALENT BONDING STRUCTURED QUESTIONS**

**Paper 2 Section A**

- 1 This question concerns the chemistry of carbon and silicon, elements from Group IV of the Periodic Table.

**Table 2.1** provides some information on two different forms of carbon (allotropes) and silicon:

<b>Substance</b>	<b>Melting point / °C</b>	<b>Electrical conductivity</b>	<b>Uses</b>
Carbon allotrope <b>A</b>	Above 3000	Poor	Cutting tools, drill bits
Carbon allotrope <b>B</b>	Above 3000	Good	Lubricant
Silicon	1414	Good	Semiconductors in electronics

- (a) Carbon tends to form covalent compounds.

By drawing the dot-and-cross diagram of a carbon compound of your choice, describe how a covalent bond is formed. You only need to show valence electrons.

Any appropriate compound

1 mark for correct number of electrons on carbon atom

1 mark for correct number of electrons on the other atom(s)

Explanation: the carbon atom and X atom share a pair of electrons to attain a noble gas electronic configuration [1]

[3]

- (b) Explain, in terms of structure and bonding, why carbon allotrope **A** can be used as a drill bit while carbon allotrope **B** can be used as a lubricant.

In allotrope A, every carbon atom is bonded to 4 other carbon atoms by strong covalent bonds. This makes the whole structure very hard.

In allotrope B, every carbon atom is bonded to 3 other carbon atoms in hexagonal layers. Little force is needed to overcome these weak intermolecular forces of attraction between layers, making B slippery.....

[2]

- (c) Carbon is commonly used as a reducing agent. For example, it can reduce zinc oxide to form zinc.

Explain, using oxidation states, how carbon is acting as a reducing agent in the reduction of zinc oxide.

Carbon causes the oxidation state of zinc to decrease from +2 in ZnO to 0 in Zn, hence reducing zinc oxide IC itself is oxidized. O.S of C increases from 0 to +2. Hence it's a reducing agent

[1]

[Total: 6 marks]

**Paper 2 Section B**

- 1 Silicon dioxide, also known as silica, is a chemical compound that is an oxide of silicon. Silica, in the form of sand is used as the main ingredient in sand casting for the manufacture of various metallic components in engineering.

A diagram of a silicon dioxide is shown below.

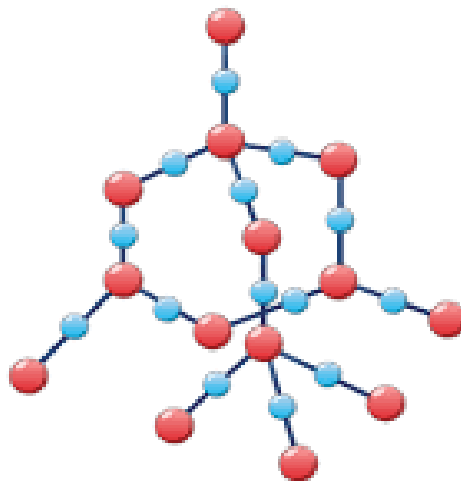

- (a) State one similarity and one difference between the structure of silicon dioxide and structure of diamond.

Both has a giant tetrahedral arrangement OR  
There are strong covalent between atoms in both silicon dioxide and diamond. [1]

Silicon dioxide is made of silicon and oxygen atoms covalently bonded together whereas diamond is made up of only carbon atoms covalently bonded together. [1]

[2]

- (b) Both diamond and silicon dioxide are poor electrical conductors.

State the name of another form of carbon which can conduct electricity.

How is this form of carbon different in structure from silicon dioxide which allows it to conduct electricity?

Graphite [correct but no marks]

Each carbon atom in graphite uses only 3 out of its 4 valence electrons for covalent bonding. There is one delocalized electron form each carbon atom which is free to move to carry electric charges whereas there are no free electrons in silicon dioxide to carry electric charges. [1] [2]

- (c) Soda-lime glass is made by heating a mixture of calcium carbonate, sodium carbonate and sand in a furnace to a high temperature.

Other glasses contain compounds called silicates. The structures of soda-lime glass and silicate are shown in **Fig. 9**

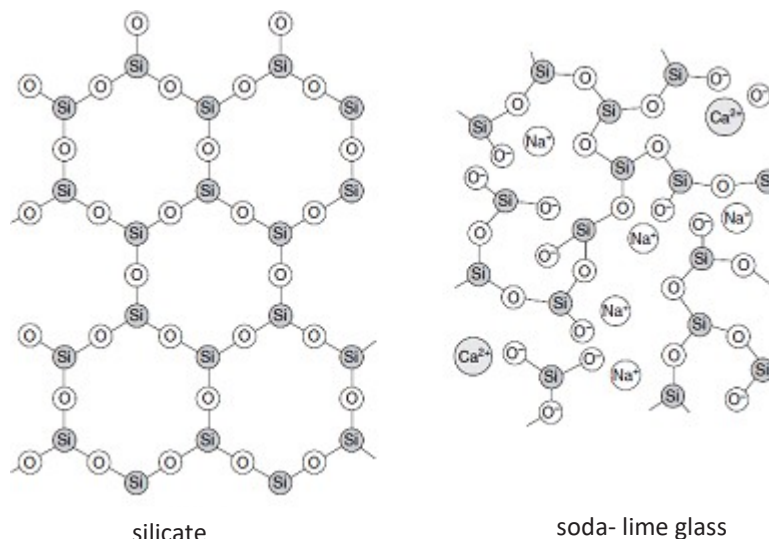

**Fig.9**

- (i) State one structural difference between soda-lime glass and silicate. [1]

silicate	soda-lime glass
Has regular arrangement of atoms/ arranged in hexagonal rings	Has irregular arrangement of atoms /ions
Absence of ions	Presence of calcium/ sodium ions
All the oxygen atoms are each covalently bonded to 2 silicon atoms	Some oxygen atoms are covalently bonded to only one silicon atom
Contains covalent bonds	Contains covalent and ionic bonds

Any one difference

- (ii) Is soda-lime able to conduct electricity? Explain your answer.

It is not able to conduct electricity in the solid state but is able to conduct electricity in the molten state. [1] **[Reject aqueous state]**

In the solid state, the calcium and sodium ions are in fixed positions and are not free to move to conduct electricity.[1]

In the molten state, the ions are free to move to conduct electricity. [1] [3]

[Total: 8 marks]

2 Read the information below about the chlorides of elements in Period 3 of the Periodic Table.

### Elements and their chlorides

The formulae and chemical properties of the chlorides of the elements change across Period 3.

The chlorides behave differently when they are added to water. Some the chlorides dissolve in water to form a solution. Some hydrolyse when they are added to water. This means that they react chemically with water to produce new products.

element	metal / non-metal	formula of main chloride	bonding in chloride	effect of adding chloride to water	products of adding chloride to water
Na	metal	$\text{NaCl}$	ionic	dissolves	$\text{NaCl(aq)}$
Mg	metal	$\text{MgCl}_2$	ionic	dissolves	$\text{MgCl}_2\text{(aq)}$
Al	metal	$\text{AlCl}_3$	covalent	hydrolyses	Complex mixture of products including $\text{HCl(aq)}$
Si	non-metal	$\text{SiCl}_4$	covalent	hydrolyses	$\text{SiO}_2\text{(s)}$ $\text{HCl(aq)}$
P	non-metal	$\text{PCl}_3$	covalent	hydrolyses	$\text{H}_3\text{PO}_3\text{(aq)}$ $\text{HCl(aq)}$
S	non-metal	$\text{S}_2\text{Cl}_2$	covalent	hydrolyses	complex mixture of products including $\text{HCl(aq)}$
Cl	non-metal	$\text{Cl}_2$	covalent	hydrolyses	$\text{HClO(aq)}$ $\text{HCl(aq)}$

The chlorides have a different formulae and the ratio of the element to chlorine changes across Period 3. Some examples are shown in the table below.

formula of chloride	ratio of element to chlorine
$\text{NaCl}$	1:1
$\text{MgCl}_2$	1:2
$\text{AlCl}_3$	1:3

- (a) Describe the pattern for the ratio of each element to chlorine across period 3. Include ratios in your answer.

Across period 3, the ratio of each element to chlorine decrease from 1:1 in NaCl to 1:4 in SiCl<sub>4</sub> respectively [1] and then increased from 1:3 to 1:1 in PCl<sub>3</sub> to S<sub>2</sub>Cl<sub>2</sub> [1] [2]

- (b) (i) Which chloride forms a precipitate when it is added to water?

Silicon tetrachloride or silicon(IV) chloride or SiCl<sub>4</sub> [1]

- (ii) Write a balanced equation for the reaction of phosphorus (III) chloride with water.



- (c) Two students talk about the data.

Student 1: 'I think that whether or not the chloride hydrolyses is linked to the metal or non-metal character of the element.'

Student 2: 'I think that whether or not the chloride hydrolyses is linked to the bonding of the chloride.'

Does the information in the table support the ideas of the students? Explain your reasoning.

The information supports the idea of student 2 but not student 1

The information supports student's 2 idea as covalent chlorides formed from aluminium to sulfur hydrolyse [1] whereas ionic chlorides like those of sodium and magnesium only dissolve. [1]

The information does not support student 1 as chlorides of both metals like aluminum and non-metals from silicon to sulfur hydrolyse. [1] [3]

- (d) Another student performs an experiment to test whether some other chlorides dissolve or hydrolyse when they are added to water.

He adds each chloride to water and tests the pH of the mixture.

Explain how the result of a pH test shows whether or not a chloride has hydrolysed.

Based on the information in the table, if a chloride has hydrolysed, dilute hydrochloric acid will be produced.

Hence, a pH level lower than 7 will mean that the chloride has hydrolysed. [1] If the chloride is not hydrolysed, the pH remains at 7. [1] [2]

- (e) Suggest a reason why argon is not included in the table of information about Period 3 chlorides.

Argon has a stable electronic configuration of 8 electrons in the outermost shell/ stable octet configuration

Hence, it is chemically unreactive/inert and will not react with chlorine to form a chloride. [1]

[Total: 10 marks]

- 3 The structure of a molecule of an oxide of phosphorous is shown in Fig.

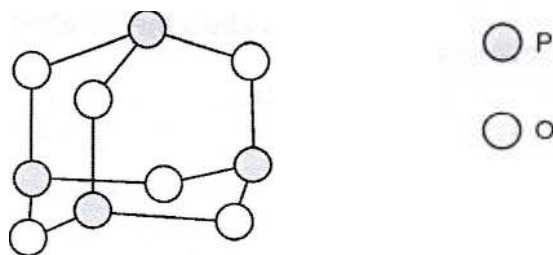

Fig. 3

- (a) Explain fully each of the following properties of this oxide of phosphorous, with reference to its bonding and structure where necessary .

**Property 1:** This oxide has a low melting point

*Explanation*

- (j) Simple molecular structure with weak intermolecular forces between molecules (ACCEPT: OWTTE with reference to structure AND interactions)
- Small amount of energy required to overcome these forces

**MR:** There were still some candidates who .,1, de reference to overcoming covalent bonds instead of th correc, interaction for simple molecular structures

[2]

**Property 2:** This oxide is acidic.

*Explanation .*

Oxide of a non-metal

[1]

- (b) State one other likely property of this oxide of phosphorous.

ANY ONE:

- Able to dissolve in or anic solvents
- Not able to dissolve in water
- Poor conductor of heat/ electricity
- Able to react with metals to form salt and hydrogen
- Able to react with carbonate or.. salt, water and carbon dioxide
- Able to react with alkalis/bases to form salt and water

**MR:** Generally well done due to the plethora of acceptable responses. However, care must be made when referencing electrical conductivity [1]

[Total: 4 marks]

- 4 (a) In the figure below, ethylamine gas,  $C_2H_5NH_2$ , reacts with hydrogen chloride gas,  $HCl$ , to form solid ethylammonium chloride, which appears as a white ring. **A**, **B** and **C** are three possible positions where the white ring can appear.

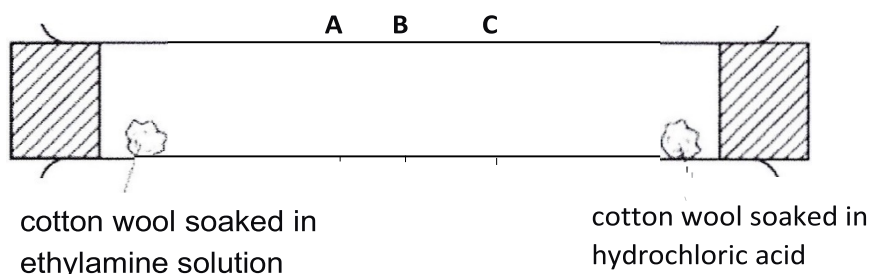

- (i) Given that **B** is the mid-point of the tube, predict the position, **A**, **B** or **C**, at which the white ring of ethylammonium chloride will form. Explain your answer.

Position A. [1]

Hydrogen chloride gas has a lower relative molecular mass than ethylamine gas. [1]

Hence, hydrogen chloride gas will diffuse more quickly than ethylamine gas. [1]

The ring would be formed closer to the cotton wool soaked in ethylamine as hydrogen chloride would be able to travel a greater distance than ethylamine in the same time.

[3]

- (ii) The reaction is repeated at a higher temperature. Predict if the position and rate at which the white ring is formed changes. Explain your answer.

The ring would form more quickly as a higher temperature increases the rate of diffusion of both gases. [1]

However, since both gases diffuse as a faster rate, there is no change in the position of the ring. [1]

[2]

- (b) (i) Graphite is a good conductor of electricity whilst diamond is not able to conduct electricity.

With reference to their bonding and structure, explain why diamond and graphite have different electrical conductivities.

In diamond, each carbon atom is bonded to four others whilst in graphite, each carbon atom is only bonded to three others. [1]

In diamond, all the valence electrons are used for bonding and there are no mobile electrons available to act as charge carriers. Hence diamond is unable to conduct electricity. [1]

In graphite, each carbon atom has 1 valence electron which is not used for bonding. These electrons are delocalised and can move and act as charge carriers. Hence, graphite is able to conduct electricity. [1]

- (ii) A diagrammatic representation of how boron and nitrogen atoms are arranged in hexagonal boron nitride is shown below.

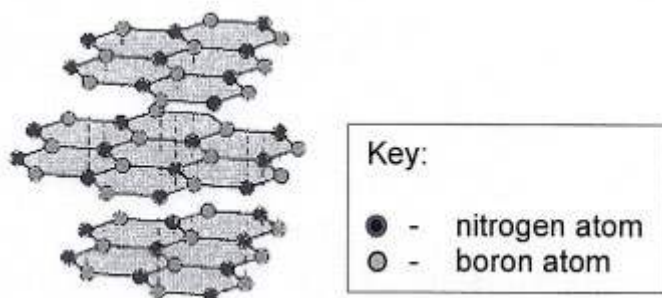

With reference to the bonding and structure in hexagonal boron nitride, suggest if it would be appropriate to use hexagonal boron nitride for manufacturing drill tips. Explain your answer.

Not appropriate. [no marks]

Hexagonal boron nitride has a layered structure, with weak forces of attraction between the (adjacent) layers. [1]

These layers slide over each other easily, making boron nitride soft and slippery, and unsuitable for use as drill tips. [1]

[Total: 10]

- 5 Carbon atoms can bond to each other to produce a variety of different structures, including diamond, graphite and buckminsterfullerene.

(a) There are similarities and differences in the structure and bonding in diamond and graphite.

- (i) Describe two features of the structure and bonding in diamond that are similar to graphite.

Both consists entirely of carbon atoms joined by covalent bonds;

Both have giant lattice (or giant molecular)

[2]

- (ii) Describe two features of the structure and bonding in diamond that are different from graphite.

In diamond every carbon atom is bonded to four other carbon atoms, but in graphite, each carbon atom is bonded to 3 atoms;

diamond has a tetrahedral arrangement of atoms but graphite has a layered arrangement;

graphite has delocalised electrons unlike diamond which do not

[2]

- (b) Buckminsterfullerene is a form carbon with the formula  $C_{60}$ . If it is burned completely in oxygen, it forms carbon dioxide as the only product.

Calculate the mass of carbon dioxide that is released when 51 g of buckminsterfullerene is completely burned in oxygen.

[2]

No. of mole of  $C_{60} = 51 / 720 = 0.0708$  (eqn – optional)

No. of mole of  $CO_2 = 60 \times \text{no. of mole of } C_{60} = 0.0708 \times 60 = 4.24$

Mass of  $CO_2 = 4.24 \times 44 = 187 \text{ g}$

(c) The structures of graphite and boron nitride are shown below.

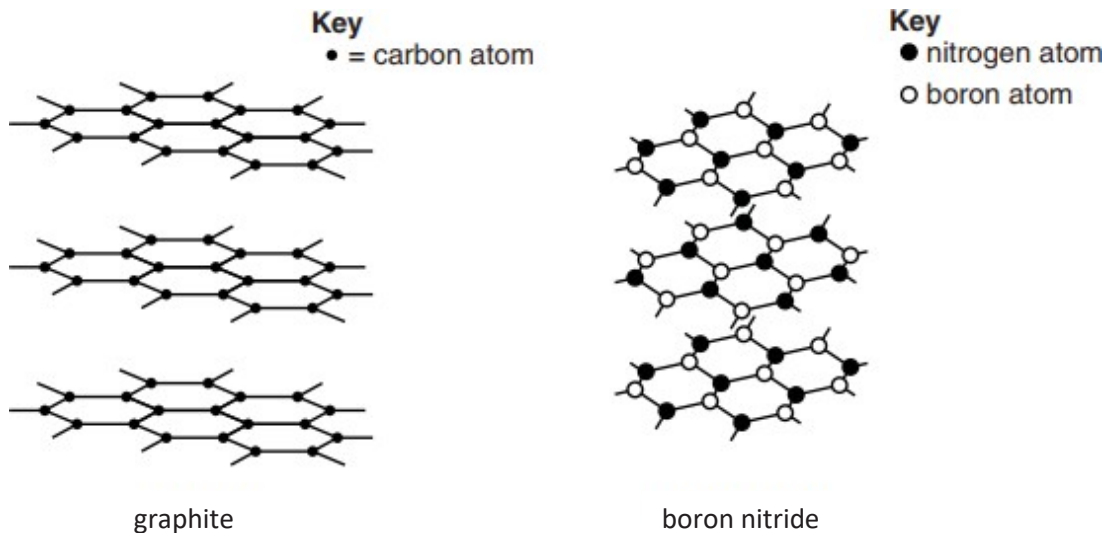

(i) What is the chemical formula for boron nitride? **BN** [1]

(ii) Like graphite, boron nitride feels slippery to the touch.

Explain, in terms of bonding and structure, why boron nitride feels slippery to touch.

**weak Van der Waal (or intermolecular) forces of attraction between layers;  
layers of atoms can slide over each other** [2]

(iii) The diagram below shows the structure of a solid form of carbon called graphene. Graphene contains **one layer** of carbon atoms. Graphene is made from graphite but it is harder than graphite.

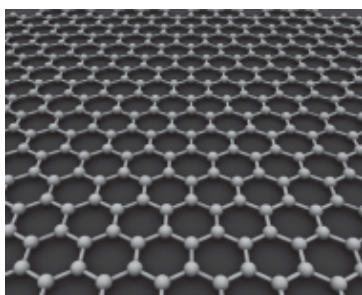

Explain, using ideas about structure and bonding, why graphene is hard.

**graphene has many strong covalent bonds between carbon atoms ...**[1]

6 The following table shows some substances and their properties.

substance	melting point (°C)	boiling point (°C)	solubility in water	electrical conductivity	
				when solid	when liquid
<b>A</b>	3550	4830	insoluble	poor	poor
<b>B</b>	-55.6	-78.5	slightly soluble	poor	poor
<b>C</b>	1085	2562	insoluble	good	good
<b>D</b>	801	1413	soluble	poor	good
<b>E</b>	-38.8	357	insoluble	good	good

(a) Using the letters **A, B, C, D** and **E**, which substance(s) is/are likely to have a

(i) simple molecular structure, ...**B**..... [1]

(ii) giant covalent structure,.....**A**..... [1]

(iii) giant metallic structure **.C and E...**  
Note: both answers must be correct to award 1 mark [1]

(b) Suggest a possible identity for element **E**. [1]

**Mercury**

(c) A student passed a current through molten substance **D** and after a while, a gas which rekindled a glowing splint was produced at the anode.

Write an ionic half-equation, including state symbols, for the reaction that happened at the anode.



Note: [1] for chemically balanced ionic equation without state symbols. [2]

[Total: 6]

7 (a) Silicon has three naturally occurring isotopes. Complete Table 3.1 for two of these isotopes.

Table 3.1

isotope	$^{28}\text{Si}$	$^{30}\text{Si}$
atomic number	<b>14</b>	14
number of neutrons	14	<b>16</b>
nucleon number	<b>28</b>	<b>30</b>

[2]

**[1 m for every 2 correct answers; max. of 2 m]**

(b) Silicon(IV) chloride is a simple molecular compound and exists as a liquid at room temperature.

(i) Suggest **two** physical properties of silicon(IV) chloride, other than solubility.

low melting point and boiling point

poor electrical conductor / cannot conduct electricity / good insulator [2]

(ii) Draw a diagram to show the arrangement of electrons in a molecule of silicon(IV) chloride. You only need to show outer shell electrons.

low melting point and boiling point

poor electrical conductor / cannot conduct electricity / good insulator

low melting point and boiling point

poor electrical conductor / cannot conduct electricity / good insulator

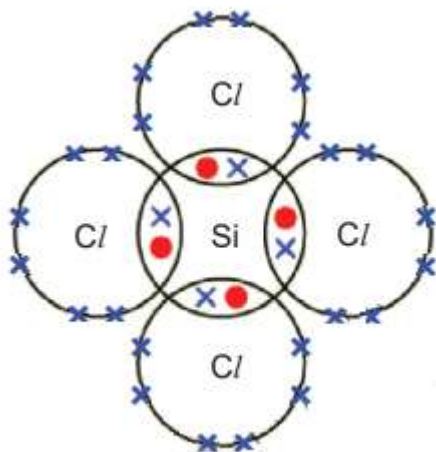

[2]

(c) Silicon(IV) chloride reacts with water to form silicon(IV) oxide and an acidic product.

Fig. 3.2 shows part of the structure of silicon(IV) oxide.

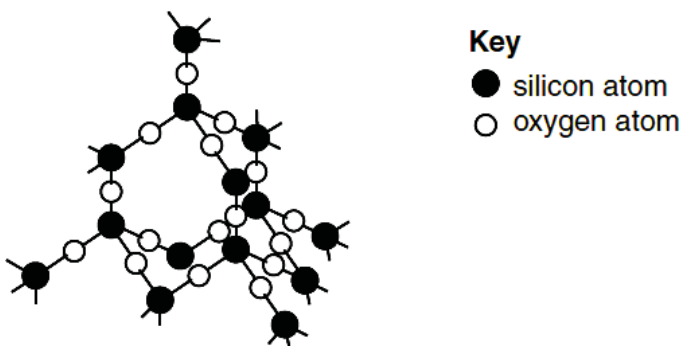

Fig. 3.2

- (i) Construct an equation, including state symbols, for the reaction between silicon(IV) chloride with water.



- (ii) A student claims that the physical properties of silicon(IV) oxide is similar to that of silicon(IV) chloride.

Explain, in terms of structure and bonding, why the student's claim is wrong.

1 m for mentioning SiO<sub>2</sub> having a three-dimensional giant molecular structure

(Whereas SiCl<sub>4</sub> has a simple molecular structure)

1 m for any following description related to bonding:

- each silicon atom is covalently bonded to 4 oxygen atoms and each oxygen atom is covalently bonded to 2 silicon atoms
- the strong covalent bonds in silicon(IV) oxide are difficult to overcome and hence, has a high melting point, unlike silicon(IV) chloride which has weak van der Waals forces of attraction / weak intermolecular forces of attraction between the molecules that is easy to overcome and hence, has a low melting point [2]

[Total: 10]

8 Each of the letter's **P**, **Q**, **R**, **S** and **W** represents a particular substance.

Answer the questions by referring to the data given in the table below.

Substance	Melting Point (°C)	Boiling Point (°C)	Electrical Conductivity		Reaction with water	Effect of heat
			solid state	liquid state		
<b>P</b>	800	1413	Non-conductor	Good conductor	Soluble in water to form a neutral solution	Melts on heating but no new substance is formed.
<b>Q</b>	63	967	Good conductor	Good conductor	Reacts with cold water, producing hydrogen and an alkali	Burns easily, forming an oxide which dissolves in water to form an alkali
<b>R</b>	-110	45	Non-conductor	Non-conductor	Insoluble in water	Burns easily, producing carbon dioxide and water
<b>S</b>	1677	2230	Non-conductor	Non-conductor	Insoluble in water	Melts without forming any new substance
<b>W</b>	2580	2850	Non-conductor	Good conductor	Soluble in water to form an alkali	Melts without forming any new substance

(a) Which substance exists as simple molecules?     **R**     [1]

(b) Which substance is a metal?     **Q**     [1]

(c) Which substance has a macromolecular structure?     **S**     [1]

(d) List the ionic compounds     **P and W**     [1]

(e) Name the particles present in **Q** that allows it to conduct electricity. [1]

**electrons**

(f) Name the two elements that must be found in substance **R**. [1]

**carbon and hydrogen**

- 9 P, Q, R, X, Y and Z are consecutive elements of the Periodic Table. The table below shows the formulae of the oxide compounds of these elements.

element	formula of oxide
<b>P</b>	<b>PO<sub>2</sub> and PO</b>
<b>Q</b>	<b>Q<sub>2</sub>O<sub>5</sub></b>
<b>R</b>	<b>RO<sub>3</sub></b>
<b>X</b>	<b>X<sub>2</sub>O<sub>7</sub></b>
<b>Y</b>	does not form any oxide
<b>Z</b>	<b>Z<sub>2</sub>O</b>

- (a) In which Group of the Periodic Table would you expect to find

(i) element **P** : Group 14 [1]

(ii) element **Y** : Group 0 [1]

(iii) element **Z** : Group 1 [1]

- (b) What is the formula of the compound formed between the elements **P** and **X**? [1]



- (c) Which of the oxide in the table above is an ionic compound? Give a reason for your answer. [2]

**Z<sub>2</sub>O** [accept **Z** as well] [1]. **Z**, a Group 1 element in the Periodic Table is a metal which combines with oxygen, a non-metal to form an ionic compound [1].

- (d) Write a balanced chemical equation to show the reaction of element **Z** in air to form **Z<sub>2</sub>O**. [1]

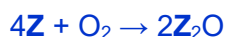

- 10 The table below shows the atomic number and mass number of element **X** and **Y** (which are not the real symbols of the elements).

element	atomic number	mass number
<b>X</b>	7	14
<b>Y</b>	17	35

- (a) Write the electronic configuration of **X**. [1]

2, 5

- (b) To which group of the Periodic Table does **Y** belong? Give a reason for your answer. [2]

Group 17 [1]. **Y** has 7 valence/ outermost electrons/ **Y** has an electronic configuration of 2, 8, 7 [1].

(c) Draw a 'dot-and-cross' diagram to represent the electronic structure of the compound formed between **X** and **Y**.

[2]

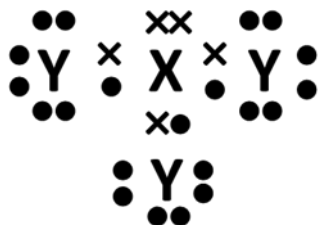

11 The table below shows the atomic number and mass number of elements **X** and **Y** (which are not the symbols of the elements).

element	atomic number	mass number
<b>X</b>	12	24
<b>Y</b>	17	35

Using the information given, answer the following questions.

(a) Write the electronic configuration of **Y**.

[1]

2, 8, 7

(b) Write down the formula for the oxide of **X**.

[1]

XO

(c) (i) What is the type of bonding that is present in the compound formed by **X** and **Y**? Give an explanation for your answer.

[2]

Ionic bonds are present in the compound formed by **X** and **Y** [1].

**X**, a Group 2 element in the Periodic Table is a metal which combines with **Y**, a Group 17 element in the Periodic Table and a non-metal [1].

OR

There is a transfer of electrons from **X** to **Y** [1].

(ii) By showing **all** the electrons, draw a 'dot-and-cross' diagram to show the bonding in the compound formed by **X** and **Y**.

